

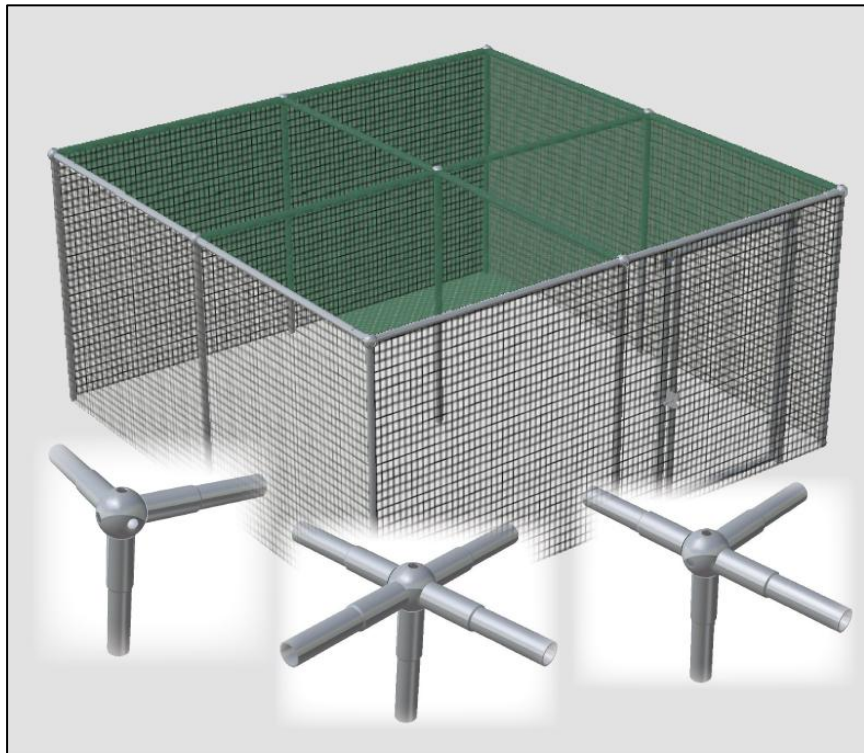

Fruit Cage Assembly Instructions



Fruit Cage Assembly Instructions

Work Safely

When you tackle a job it is important to work safely. Please consider the following points when building your Fruit Cage.

- Keep your work area tidy. A tidy site is a safe site.
- Use the correct tools for the job.
- Wear gloves where practical. Components may have sharp edges.
- Take care when using tools such as hammers, drill, knife, scissors.
- Consider other people, particularly children.

Tools Required

You will require a few tools to assemble your Fruit Cage which are usually available in most households.

- Hammer
- Cordless drill
- 13mm spanner or socket
- Tape measure
- Scissors or craft knife

Procedure

1. Choose a flat and level area to site your Fruit Cage and mark out the four corners of the Fruit Cage, ideally with string-lines.

2. With the ground tubes, make a 2m square "grid".

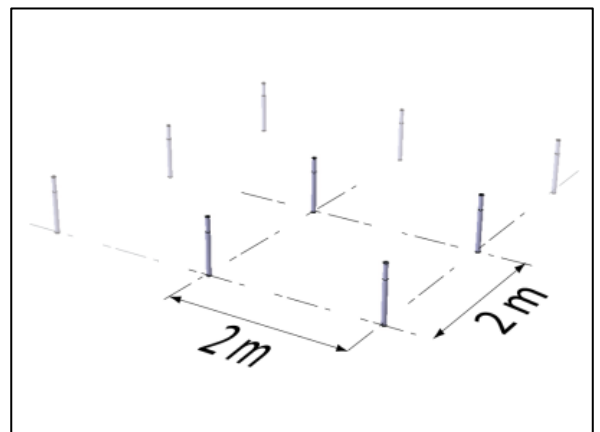
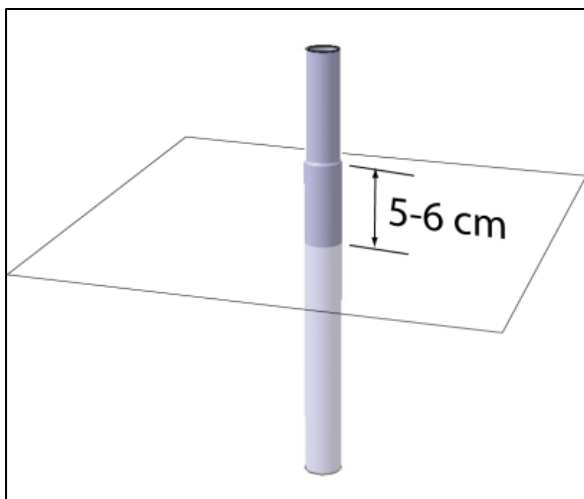

3. Hammer the swaged ground tubes into the ground until the shoulder of the swage is 5-6cm above ground level. Use a piece of wood on top of the ground tube to ensure that the tube does not become "mushroomed".

Fruit Cage Assembly Instructions

4. Slot a 185cm long tube onto each swaged ground tube.

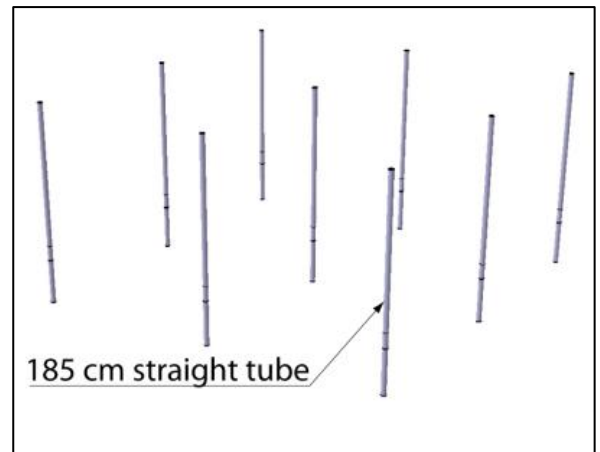
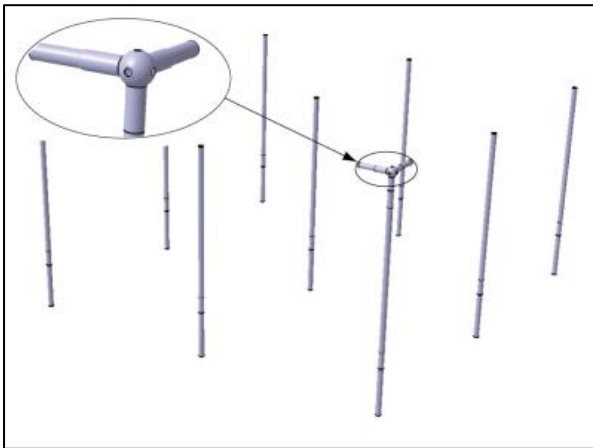

5. Start the assembly of the top framework with a corner fitting . . .

6. Then a straight tube with an intermediate fitting (for greater than 2m long) . . .

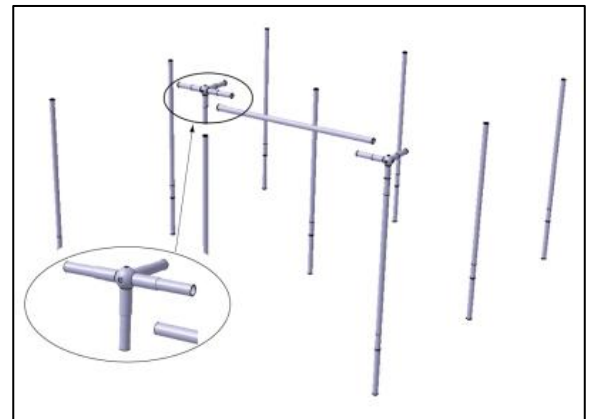
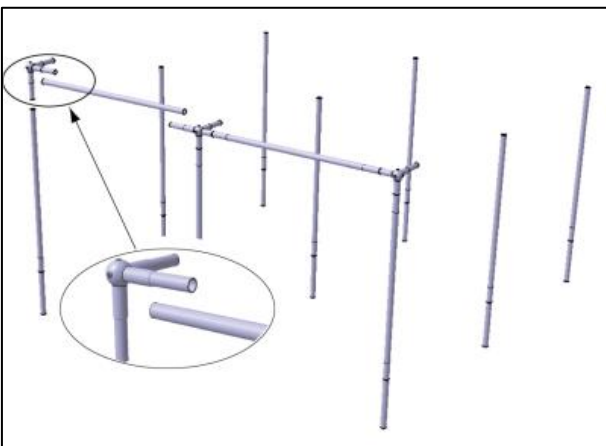

7. Finish along one side with a straight tube and corner fitting.

8. Work from the first corner with a straight tube and intermediate fitting (for Fruit Cages wider than 2m) . . .

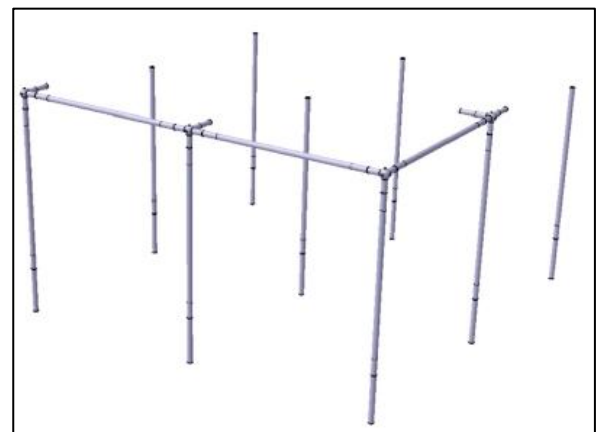

Fruit Cage Assembly Instructions

9. For Fruit Cages wider and longer than 2m, two straight tubes and a centre cross.



10. Continue until the frame is complete.

11. Assemble the door. Lay the components out on a flat surface and assemble with the fittings in the positions as shown. (Exploded view from inside.)

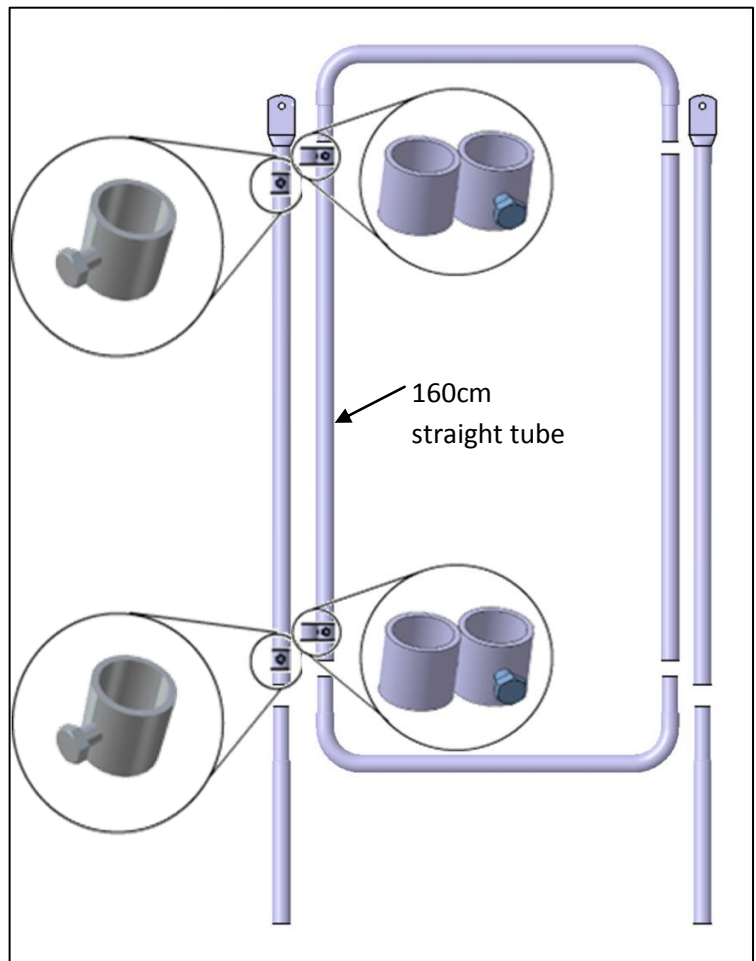

Fruit Cage Assembly Instructions

12. Fix the door corners to the straight tubes with the self-drill screws using a cordless drill.

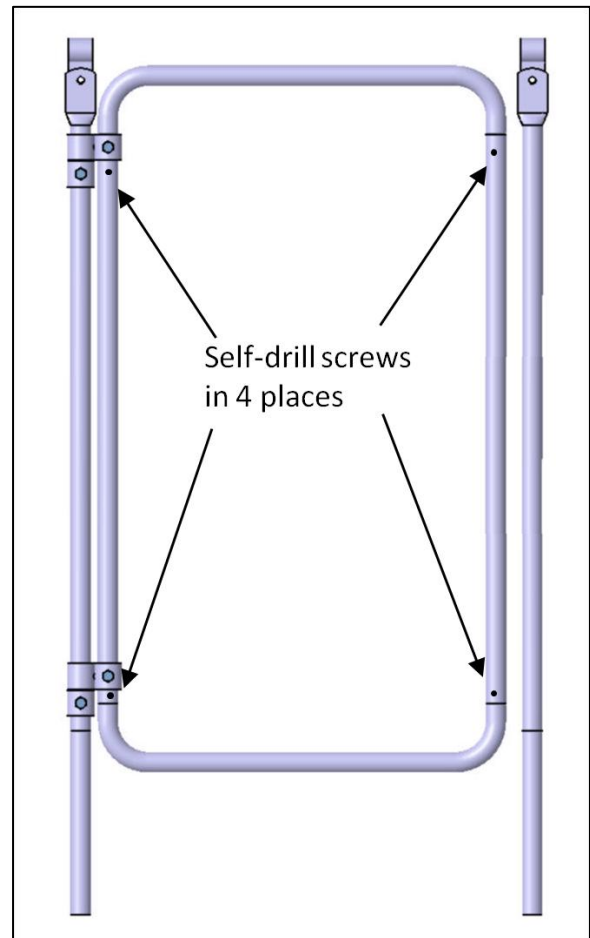

13. Fix the door assembly to the Fruit Cage framework with the KH25 fittings and M8 x 30 set screws and nylock nuts.

14. Fit the magnetic latch to the door with 2 x self-drill screws. Adjust the post so that the magnet latches securely to it.

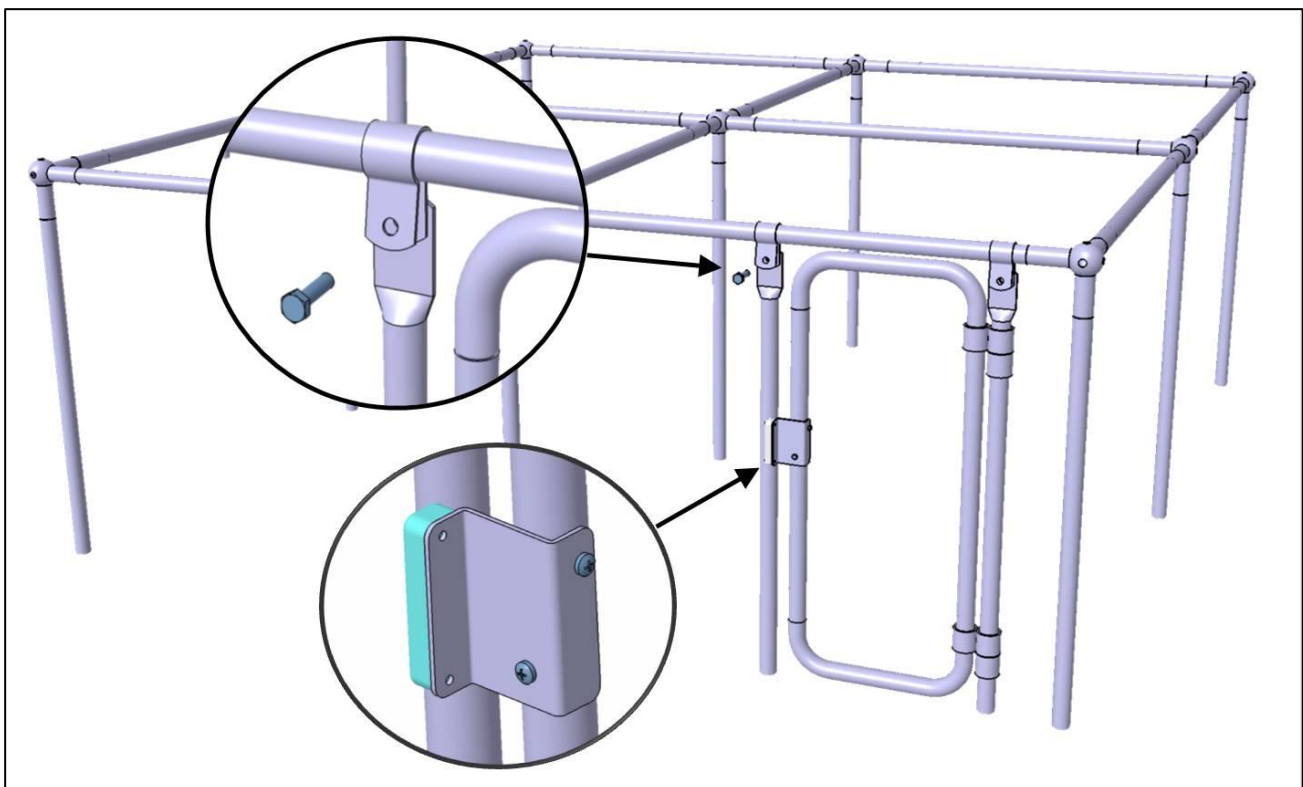

Fruit Cage Assembly Instructions

15. The side netting is supplied on a 2m long roll. With the roll stood on end, unroll the side netting around the perimeter of the fruit cage and attach to each post with a few cable ties.
16. Fix the top net ***at each corner*** with cable ties. (By doing this the net is pulled to the correct size.)

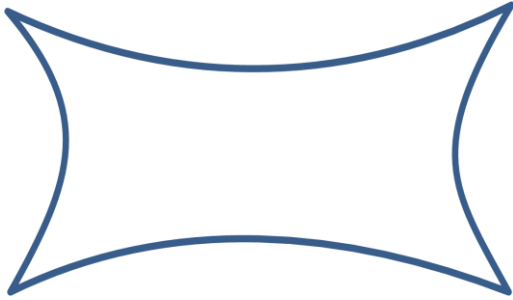

17. Then fix the top net and side net together around the top perimeter edge of the framework with cable ties at approximately 10cm apart, ***starting at mid-length/mid-width***.

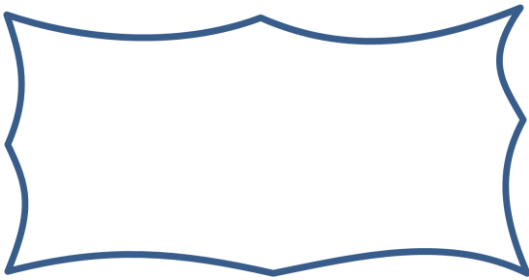

18. Fix the bottom edge of the side net using ground staples at approximately 36cm apart.

If you are unsure about any part of the assembly procedure you can contact our office between 8:30am and 5:00pm, Monday to Friday on 01282 501252.
