



## Raised Bed Assembly Instructions

### Work Safely

When you tackle a job it is important to work safely. Please consider the following points when assembling your Raised Bed.

- Keep your work area tidy. A tidy site is a safe site.
- Use the correct tools for the job.
- Wear gloves where practical. Components may have sharp edges. Timber may have splinters.
- Take care when using tools such as hammer, spade, knife, scissors.
- Consider other people, particularly children.

### Tools Required

You will require a few tools to assemble your Raised Bed and Cloche Hoop Kit which are usually available in most households.

- Hammer
- Spirit level
- Cordless drill/screwdriver
- Tape measure
- Scissors or craft knife
- Spade



## 1. SELECT THE REQUIRED BOARDS

- 1 Check what size Raised Bed you have ordered and refer to the illustrations below to see which items you require to assemble your kit.

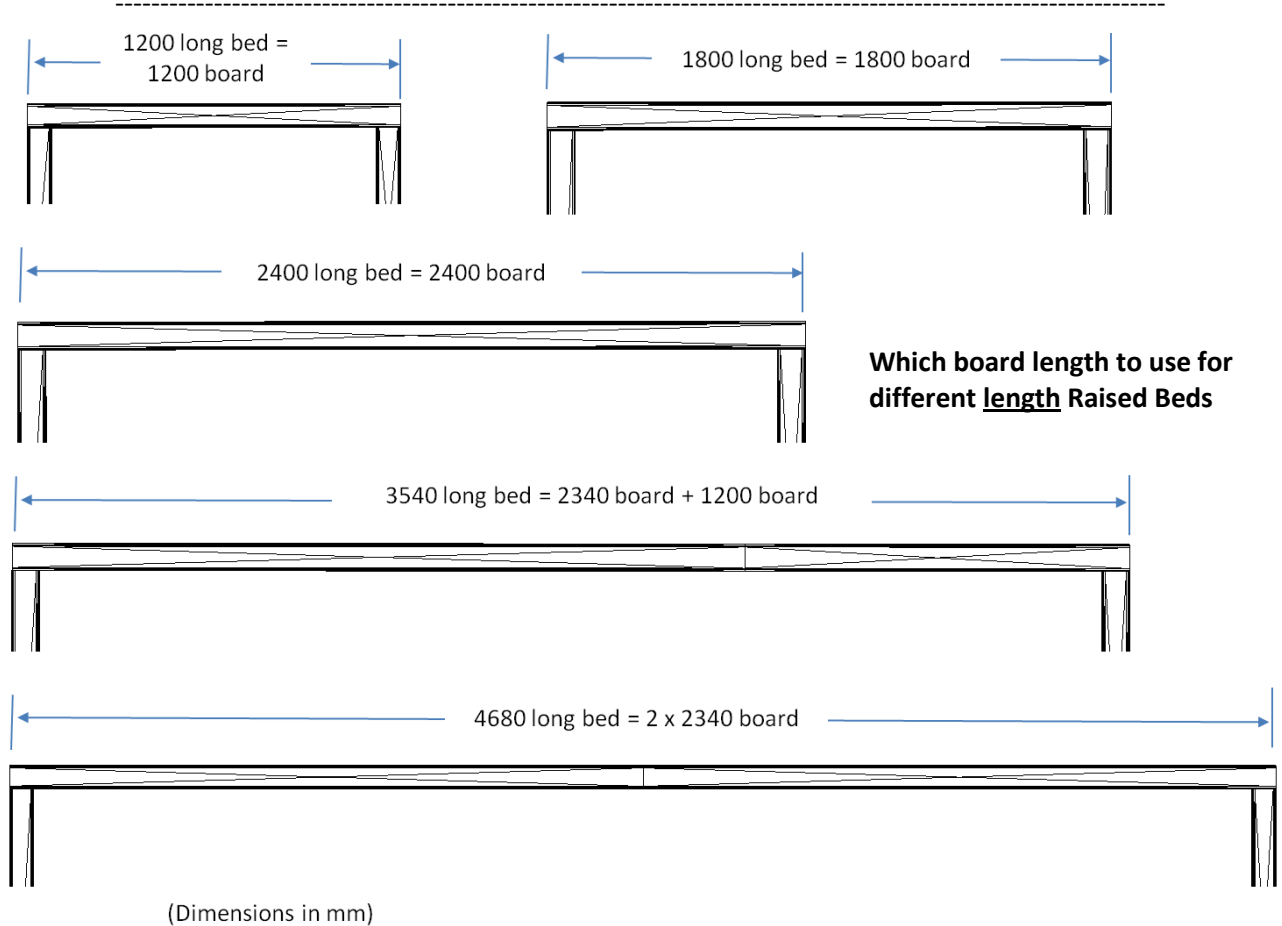
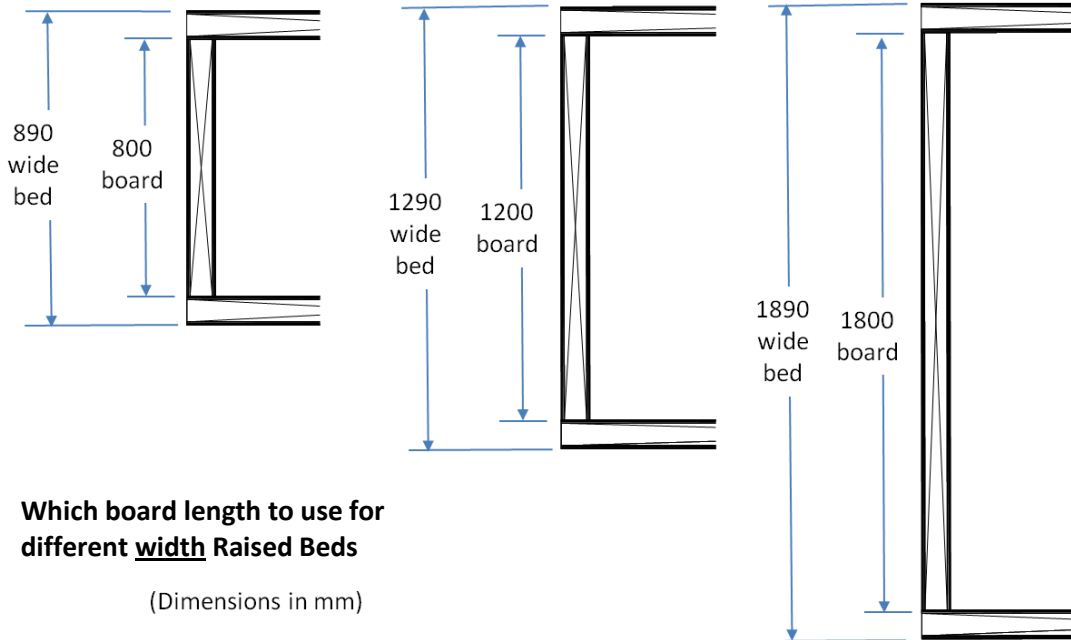

## Raised Bed Assembly Instructions

### 2. ASSEMBLE THE FIRST TIER

1. Screw the Corner Brackets onto the end boards. Make sure the top of the tube is flush with the top of the board. Make sure the face of the bracket is flush with the end of the board.

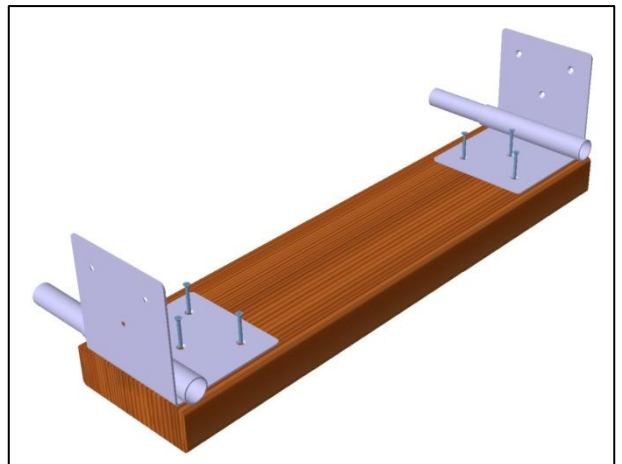

2. Screw the side boards to the end brackets.

Tip! It's easier to do this with the Raised Bed "upside-down" on a flat surface.

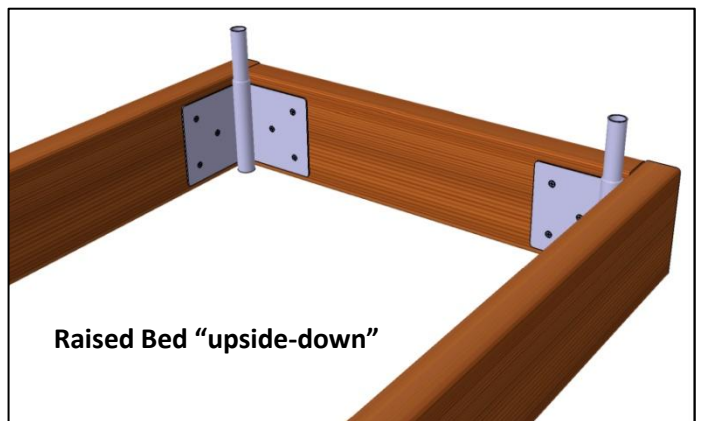

3. For Raised Beds 2400mm, 3540mm and 4680mm long, screw the Side Brackets to the side boards.

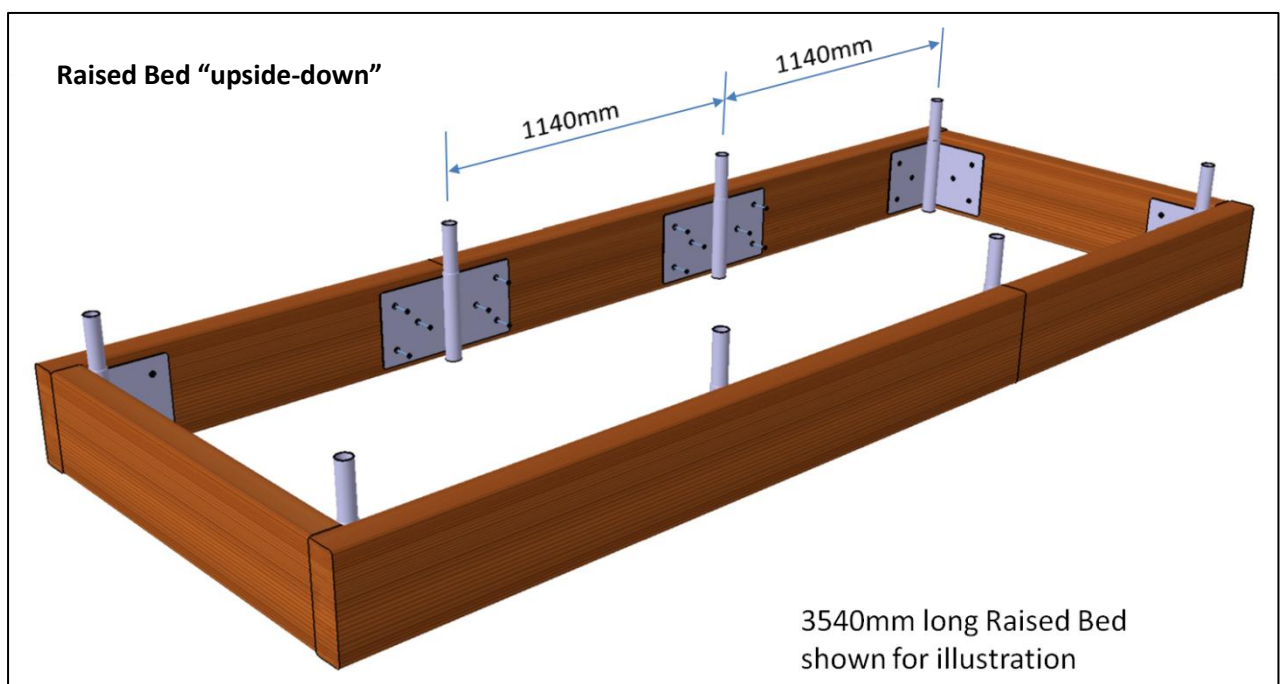

## Raised Bed Assembly Instructions

- Place the assembled Raised Bed into its location and check that it is level. Dig out the soil under the boards to level if required. Push the assembled Raised Bed down so that the tubes of the brackets are firmly in the ground.

### **3. ASSEMBLE UPPER TIERS**

With the first tier in place and level, you can build the second and subsequent tiers on top of this.

- Slot the “swaged” tube Corner Brackets (and Side Brackets) into the tube of the brackets of the previous tier.

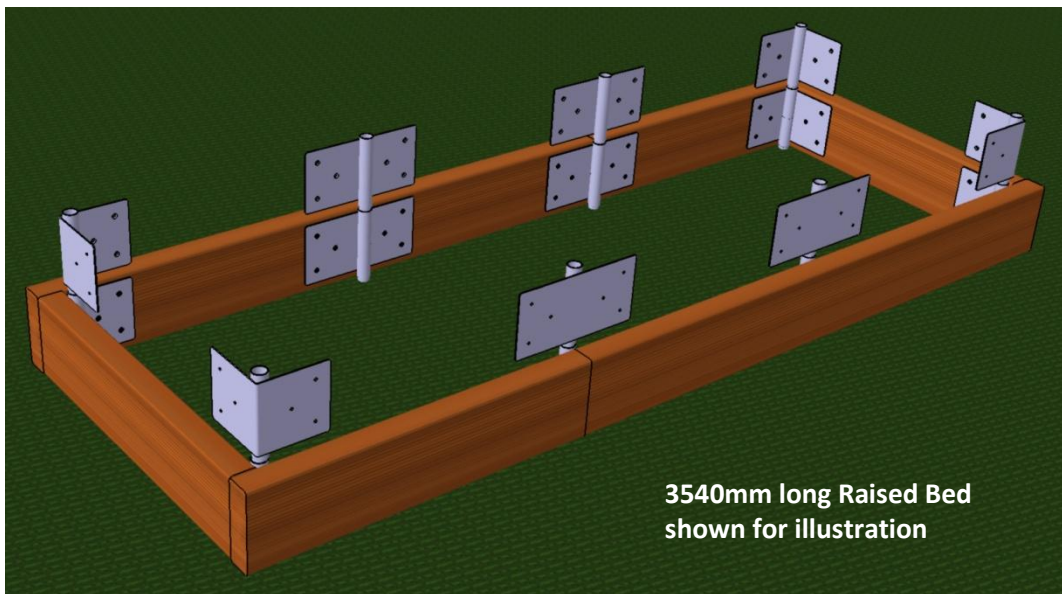

- Screw the boards of the 2<sup>nd</sup> tier to the brackets, making sure the top of the tube is flush with the top of the board.

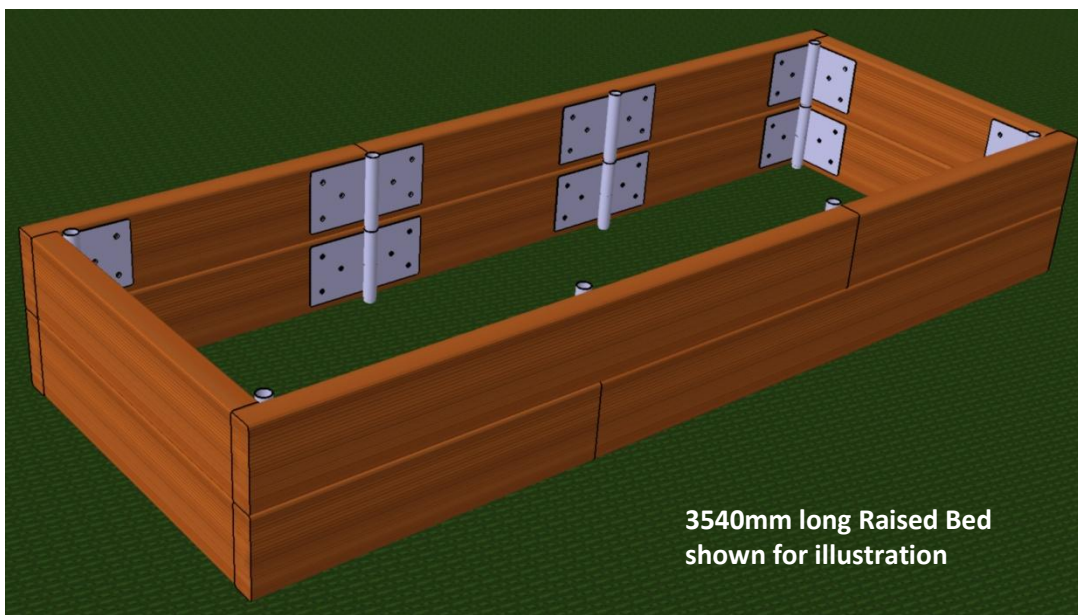

### 4. CLOCHE HOOP KIT

- 1 Screw a Screw Eye into each end board at mid-length, approximately 100mm from the top edge of the board.
- 2 For Raised Beds 2400mm, 3540mm and 4680mm long, screw a Screw Eye in line with each of the Side Brackets.

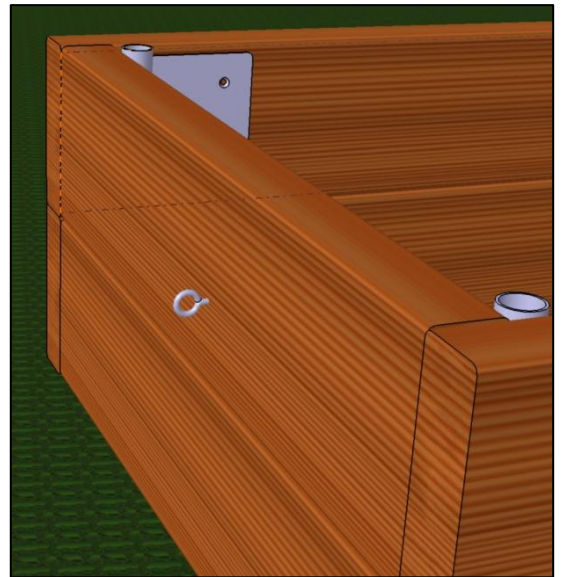
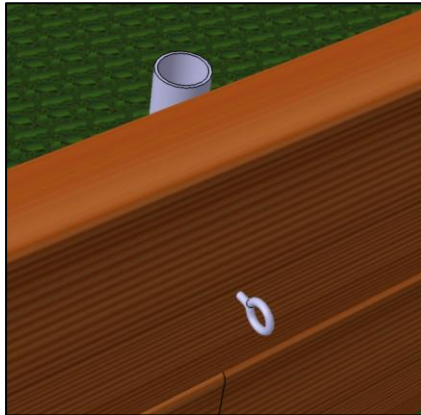

- 3 Slot the "swaged" hoops into the tubes of the Corner Brackets (and Side Brackets).
- 4 Create a loop in the Hook Tie Bungee and thread the end of the "scrunched up" polythene into the loop.



- 5 Clip the Hook Tie Bungee onto the Screw Eye on the Raised Bed end board. Pull the polythene lengthways over the hoops and fasten the polythene at the other end with the second Hook Tie Bungee.

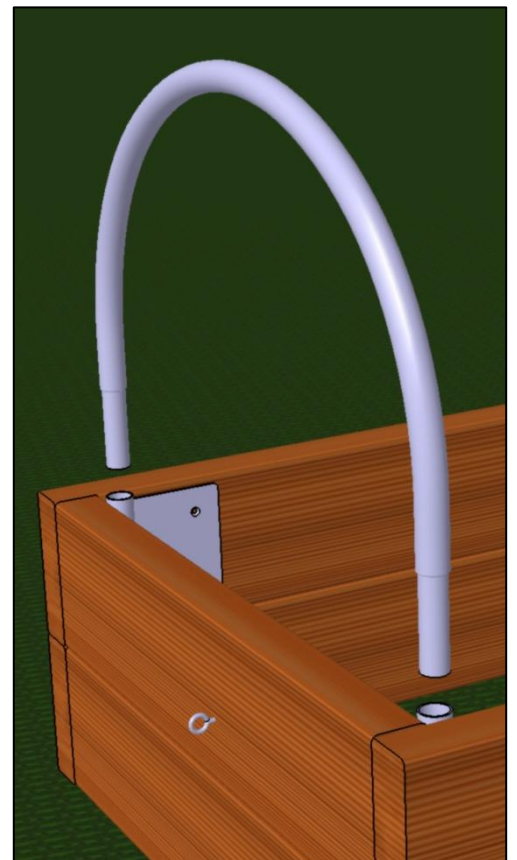

**Tip!** You can wrap the Hook Tie Bungee around the polythene 1 or 2 times to get a bit more tension.

## Raised Bed Assembly Instructions

- 6 At the positions of the inner hoops, thread the Polyester Cord through the Screw Eye, over the polythene, through the Screw Eye on the opposite side and over the polythene again. Tie off the ends of the Polyester Cord.

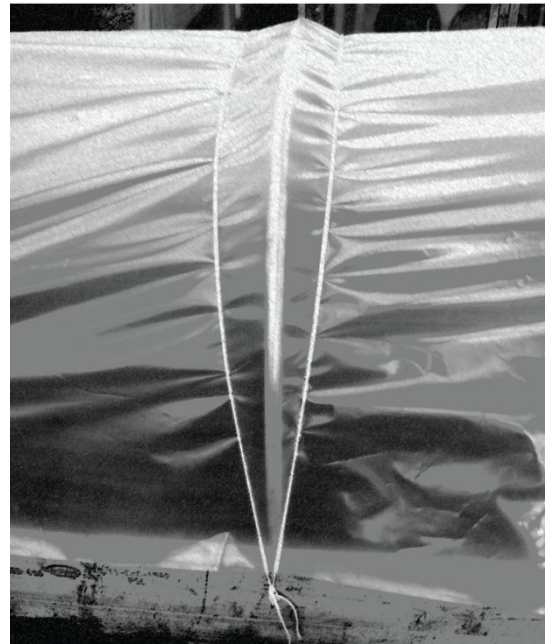

For ventilation you can raise the polythene at one or both sides.



If you are unsure about any part of the assembly procedure you can contact our office between 8:30am and 5:00pm, Monday to Friday on 01282 501252