



# Cherry Tree Cage Assembly Instructions



## Fruit Cage Assembly Instructions

### Work Safely

When you tackle a job it is important to work safely. Please consider the following points when building your Fruit Cage.

- Keep your work area tidy. A tidy site is a safe site.
- Use the correct tools for the job.
- Wear gloves where practical. Components may have sharp edges.
- Take care when using tools such as hammers, drill, knife, scissors, step-ladders.
- Consider other people, particularly children.

### Tools Required

You will require a few tools to assemble your Fruit Cage which are usually available in most households.

- Hammer
- Cordless drill
- Tall step-ladder
- Tape measure
- Scissors or craft knife

### Procedure

1. Your Cherry Tree Cage is easiest to assemble up-side-down. Start with 4 corner joiners (3-way connections) and 4 tubes at 2.35m long and slot together as shown.

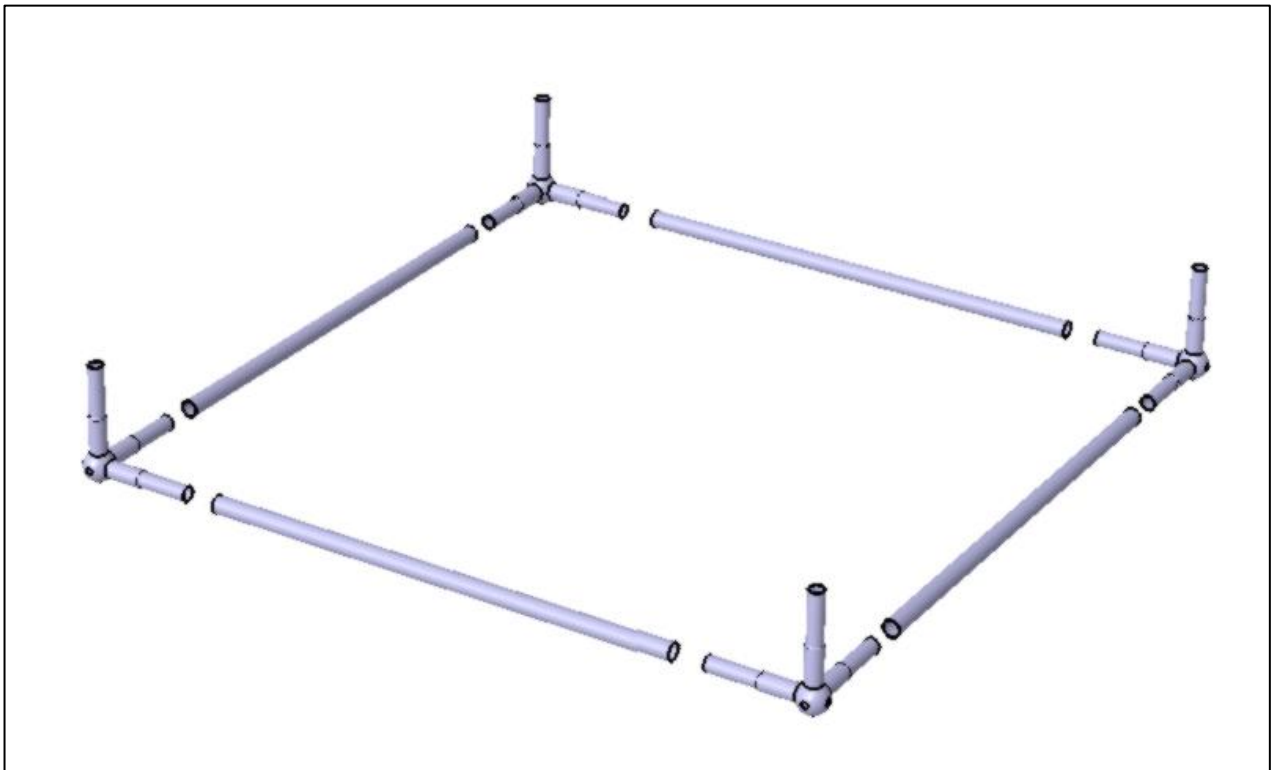

## Fruit Cage Assembly Instructions

2. As the framework is assembled, secure the tubes to the joiners:
  - Option 1 – Self-drill screws. Screw through each tube, into the joiner. The screws should be inserted on the inside of the frame to avoid the netting snagging on the screw heads.
  - Option 2 – Adhesive tape. Use the 50mm wide tape around each joint with about 3 complete wraps. Cut with scissors or a sharp knife.
  
3. Slot a 1.6m long tube onto each of the corner joiners. Slot an intermediate joiner (4-way connection) onto each of these tubes, with a 2.35m tube horizontally on 3 sides. The 4<sup>th</sup> side is left open to allow for positioning over your fruit tree.

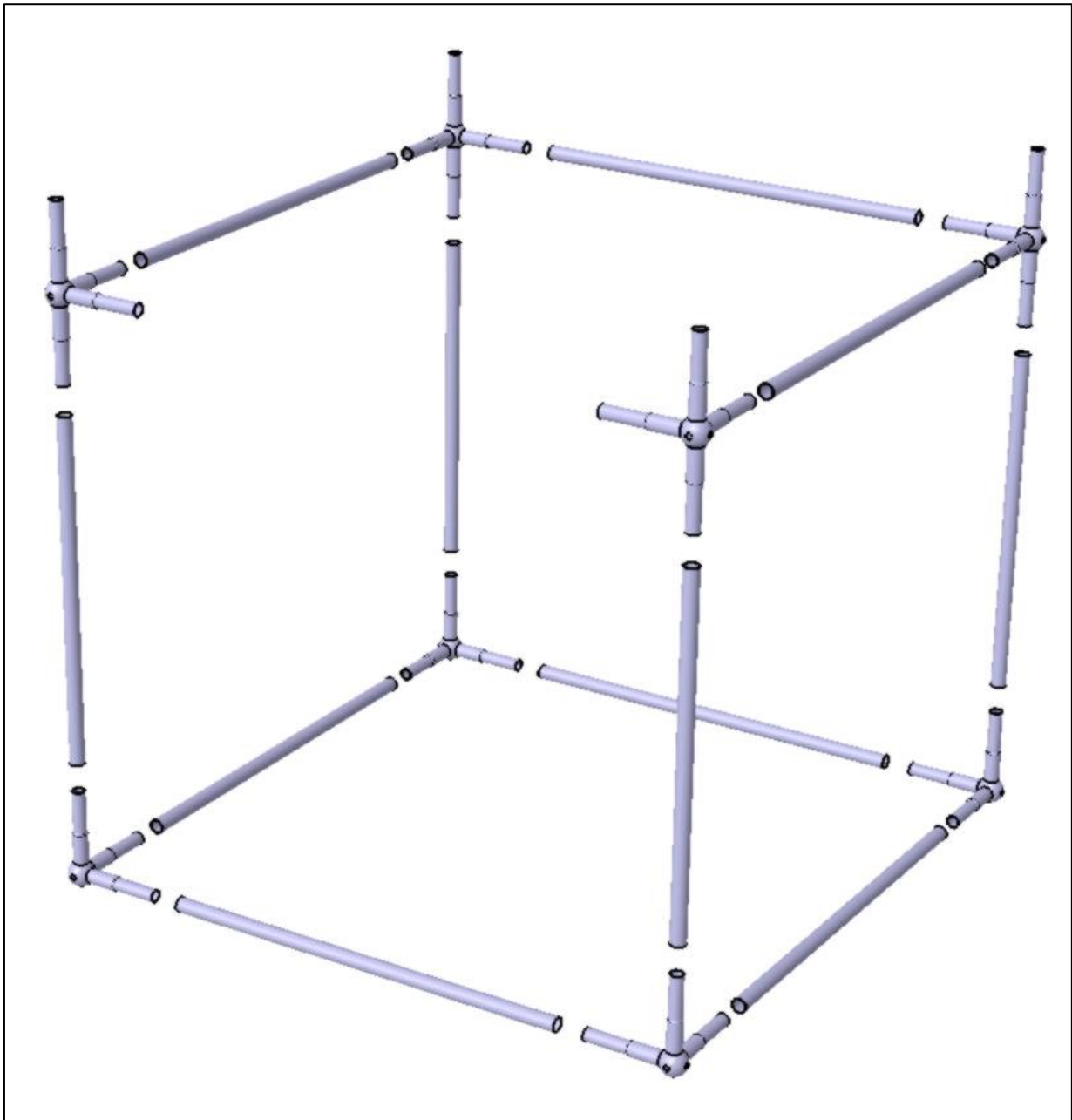

Fruit Cage Assembly Instructions

4. Slot the 4 remaining 1.6m long tubes vertically on to the intermediate joiners (4-way connections).

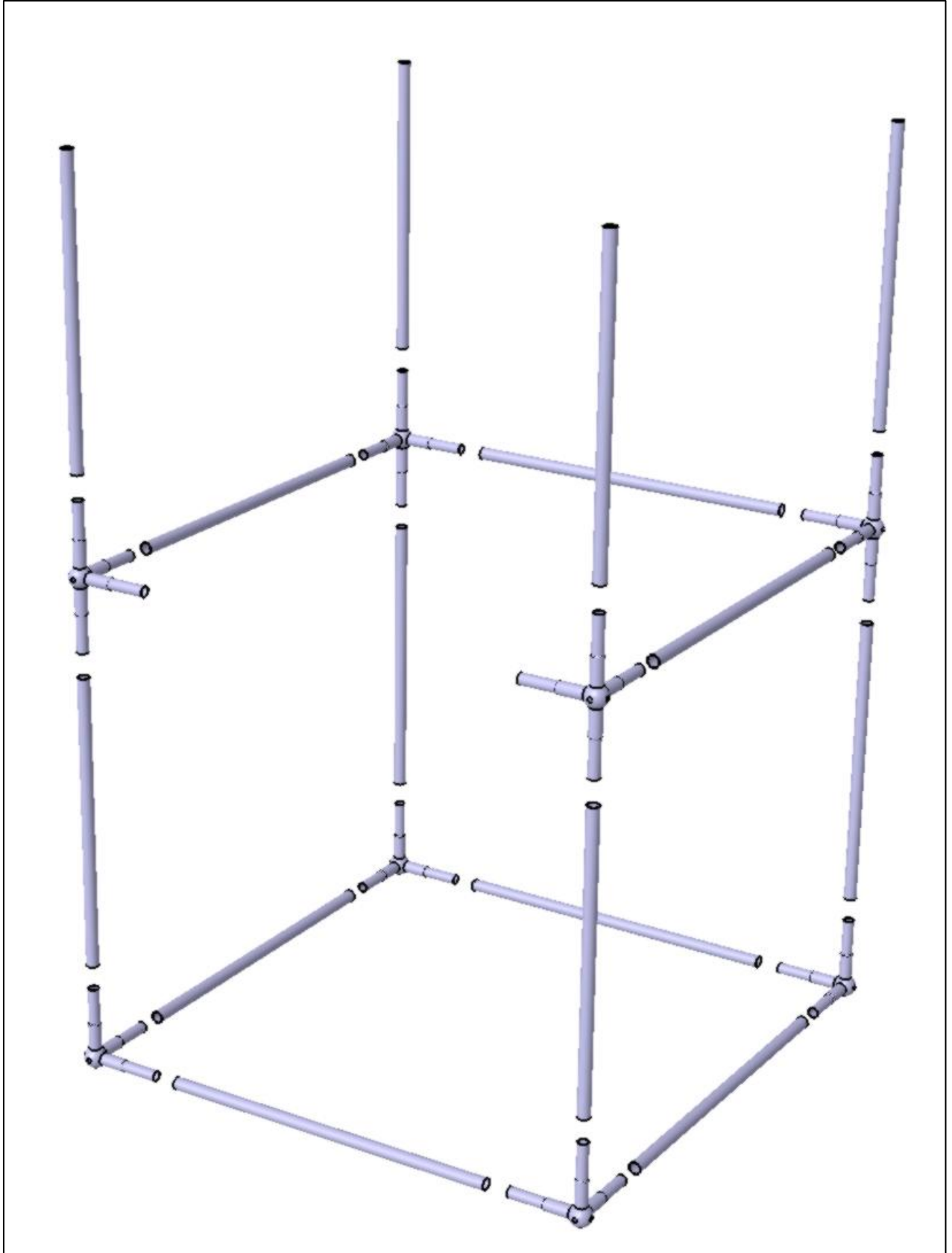

Fruit Cage Assembly Instructions

5. Turn the Cherry Tree Cage upright and position over your fruit tree. Insert the remaining 2.35m long tube. Push the legs of the framework into the ground to level the Cherry Tree Cage if required.



Fruit Cage Assembly Instructions

- The netting is fitted over the framework “diagonally”. Position the netting on top of the framework so that equal amounts drape over 2 corners.

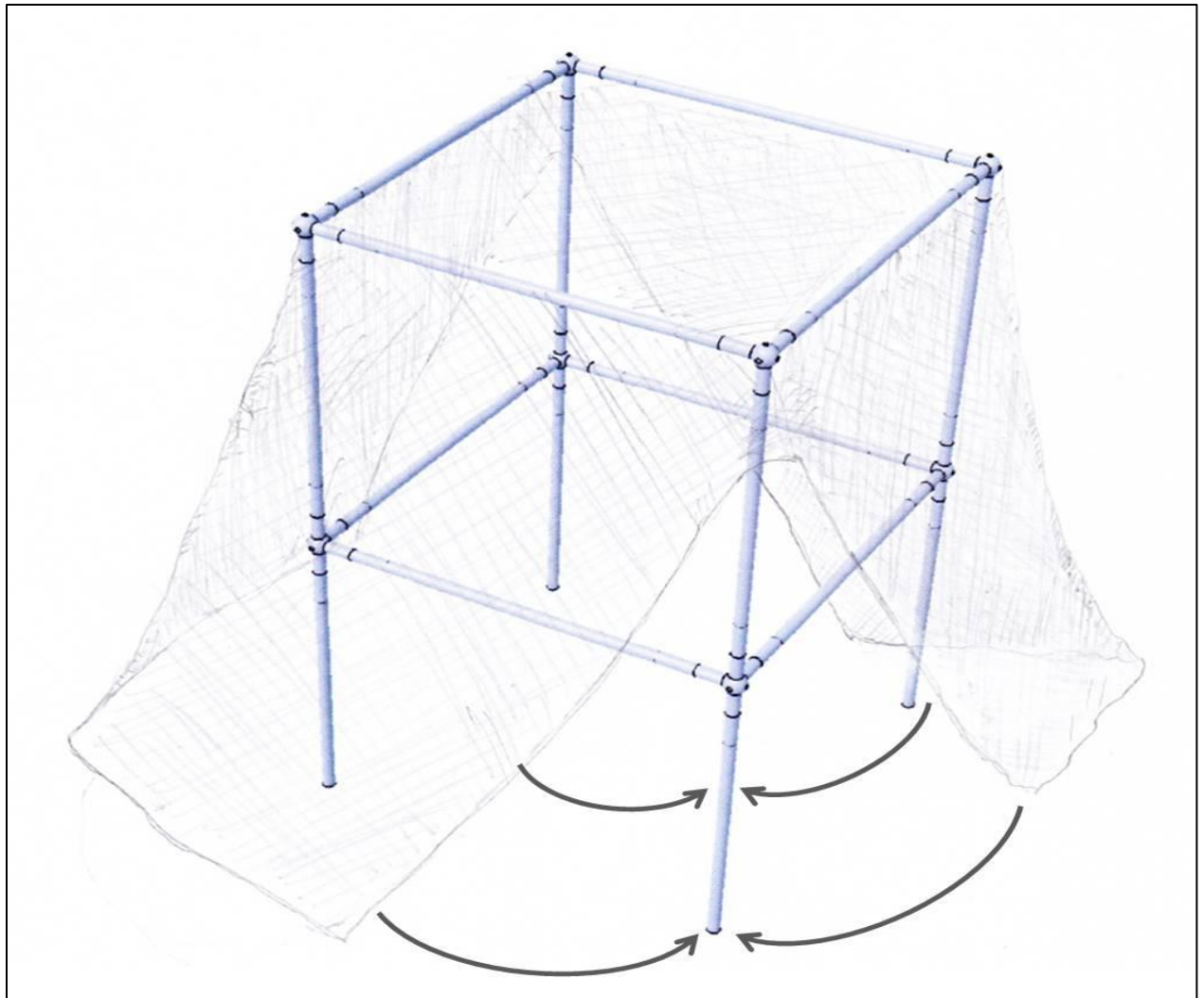

- Starting from the highest point, pull the 2 edges of the netting together and fix with the cable ties to the vertical tube. Surplus netting should be “scrunched up” – do not cut off the surplus as this can lead to fraying of the netting.
- The bottom edge of the netting is secured to the ground with the ground staples, 7 per side. Pull out the ground staples when you require access into the Cherry Tree Cage.

---

If you are unsure about any part of the assembly procedure you can contact our office  
between 8:30am and 5:00pm, Monday to Friday on 01282 501252.

---