



# 12ft Wide Polytunnel Assembly Instructions



## 12ft Wide Polytunnel Assembly Instructions

### CONTENTS

<u>Section</u>	<u>Page</u>
1. FOUNDATION TUBES: Option A – Hammered-In Foundation Tubes	3
2. FOUNDATION TUBES: Option B – Ground Anchor Plates	4
3. FOUNDATION TUBES: Option C – Concreted Foundation Tubes	5
4. STEEL FRAME ASSEMBLY & INSTALLATION	6
5. TIMBER END FRAME ASSEMBLY & INSTALLATION	8
6. TIMBER BASE RAIL (OPTION)	9
7. TIMBER SIDE RAIL (OPTION)	11
8. ROLL UP CURTAIN (OPTION)	13
9. END PANELS & SIDE NETTING (INCLUDED WITH TIMBER SIDE RAIL OPTION)	15
10. FITTING THE ANTI HOT SPOT TAPE	16
11. FITTING THE POLYTHENE – TRENCHING METHOD	17
12. FITTING THE POLYTHENE – POLYTHENE TO BASE RAIL	19
13. FITTING THE POLYTHENE – POLYTHENE TO SIDE RAIL	21
14. DOOR ASSEMBLY & INSTALLATION	23
PARTS LIST	25
POLYTUNNEL MAINTENANCE	28

### Work Safely

When you tackle a job it is important to work safely. Please consider the following points when building your Polytunnel.

- Keep your work area tidy. A tidy site is a safe site.
- Use the correct tools for the job.
- Wear gloves where practical. Components may have sharp edges. Timber may have splinters.
- Take care when using tools such as hammer, spade, drill, knife, scissors.
- Consider other people, particularly children.

### Tools Required

You will require a few tools to assemble your Polytunnel which are usually available in most households.

- Hammer
- Wood saw
- Spirit level
- Cordless drill
- 9mm drill bit
- String line (optional)
- Staple gun (optional) or stapler
- 13mm spanners or sockets
- Tape measure
- Scissors or craft knife

### 1. FOUNDATION TUBES: Option A – Hammered-In Foundation Tubes (Suitable for trenched polythene only)

- 1 Set two string lines to the width of the polytunnel (12ft apart). Ensure they are parallel.

Tip! It's best to put your polytunnel on a flat, level site. A fall lengthways is easy to accommodate. A fall sideways should be limited to about 6" over the width of the polytunnel.

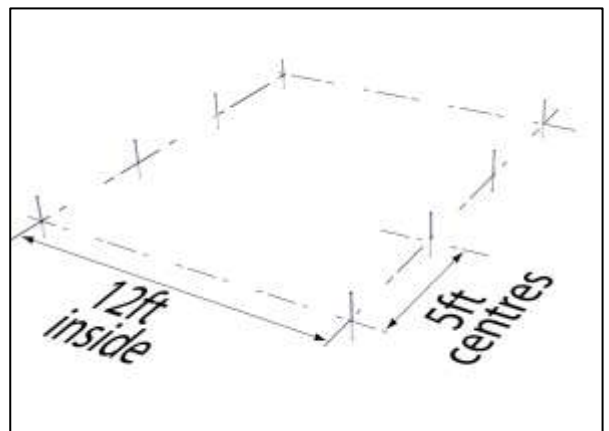

- 2 Set another string line for the end of the polytunnel. Ensure the "end" string line is perpendicular to the "length" string lines.

- 3 Hammer the first two corner Foundation Tubes into the ground. These will be positioned just outside the "length" string lines and just touching the "end" string line. Ensure the Foundation Tubes are vertical.

Tip! Use a piece of wood on top of the Foundation Tube to ensure that the tube does not become "mushroomed".

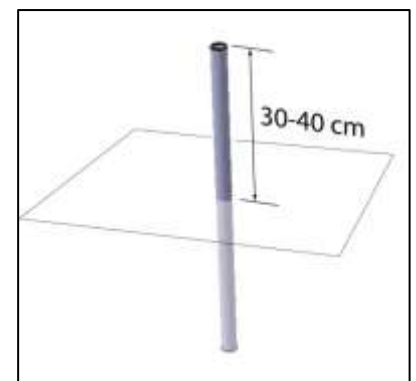

- 4 Hammer in the remaining Foundation Tubes at 5ft centres until the full length is reached.

### 2. FOUNDATION TUBES: Option B – Ground Anchor Plates

- 1 Set two string lines to the width of the polytunnel. Ensure they are parallel.

Tip! It's best to put your polytunnel on a flat, level site. A fall lengthways is easy to accommodate. A fall sideways should be limited to about 10cm over the width of the polytunnel.

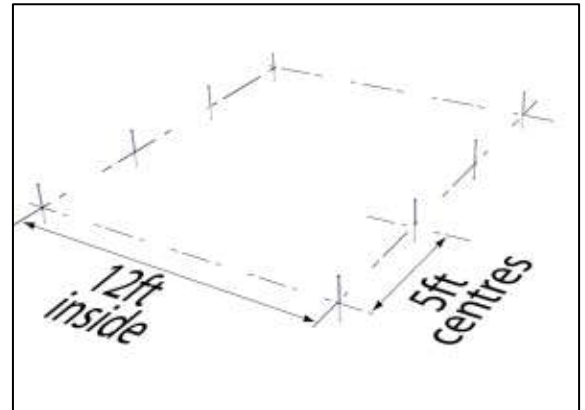

- 2 Set another string line for the end of the polytunnel. Ensure the "end" string line is perpendicular to the "length" string lines.
- 3 Mark the ground at each foundation position, to the outside of the "length" string lines at 5ft centres until the full length is reached.
- 4 Temporarily remove the string lines so they don't get in the way whilst digging.
- 5 Dig a hole for each Foundation Tube, approximately 25cm square x 35cm deep.

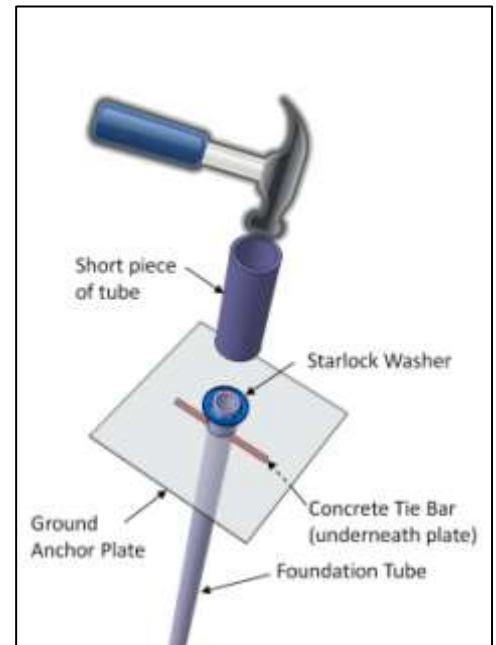

- 6 Slot the ground anchor plates onto the bottom end of the Foundation Tubes. And lock in place with the Starlock Washers. Starlock Washers are inserted using the short piece of tube.
  - a. With the foundation tube upside-down, slot the 6mm Concrete Tie Bar (steel rod) into the pre-punched hole in the Foundation Tube.
  - b. Slot the Ground Anchor Plate onto the bottom end of the Foundation Tube, to rest on the Concrete Tie Bar.
  - c. Hold the short piece of tube over the starlock washer on the bottom end of the Foundation Tube and tap the short tube with a hammer until the washer is located on the Foundation Tube, right up to the Ground Anchor Plate.
- 7 Reinststate the string lines.
- 8 Insert the Foundation Tube and anchor plate assembly into the excavated holes, to the outside of the string line. Make sure the Foundation Tubes are vertical, touching the string line and spaced at 5ft centres. The Foundation Tubes should be protruding above ground by approximately 40cm.
- 9 Backfill the excavated holes, checking that the Foundation Tubes are still in the correct position. Stamp on the soil to ensure the soil is well-compacted.

### 3. **FOUNDATION TUBES: Option C – Concreted Foundation Tubes** (Suitable for base rail or trenched polythene)

- 1 Set two string lines to the width of the polytunnel (12ft apart). Ensure they are parallel.

Tip! It's best to put your polytunnel on a flat, level site. A fall lengthways is easy to accommodate. A fall sideways should be limited to about 6" over the width of the polytunnel.

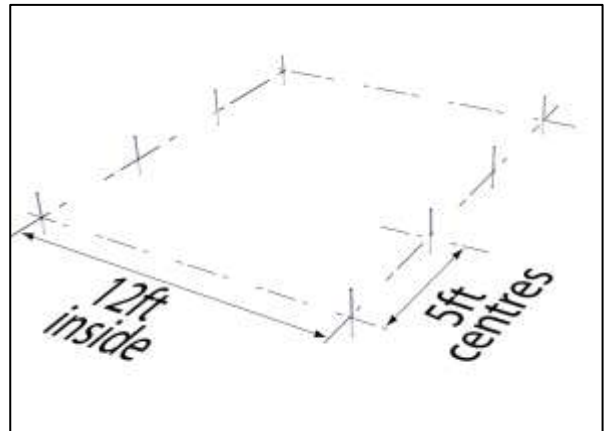

- 2 Set another string line for the end of the polytunnel. Ensure the "end" string line is perpendicular to the "length" string lines.
- 3 Mark the ground at each foundation position, to the outside of the "length" string lines at 5ft centres until the full length is reached.
- 4 Temporarily remove the string lines so they don't get in the way whilst digging.
- 5 Dig a hole for each Foundation Tube, approximately 25cm square x 35cm deep.
- 6 Reinstate the string lines.
- 7 Fill the excavated holes with freshly-mixed concrete.
- 8 Put a steel rod through the hole in the foundation tube. Slot the Foundation Tubes into the concrete, to the outside of the string lines. Make sure the Foundation Tubes are vertical, touching the string line and spaced at 5ft centres. The Foundation Tubes should be protruding above ground by approximately 40cm.

Tip! Allow the concrete to set before you try to install the framework!

## 4. STEEL FRAME ASSEMBLY & INSTALLATION

- 1 Assemble the hoops. Lay the components out on a flat surface with the fittings in the positions shown. Notice that the bolt heads are facing inwards so as not to protrude into the polythene.

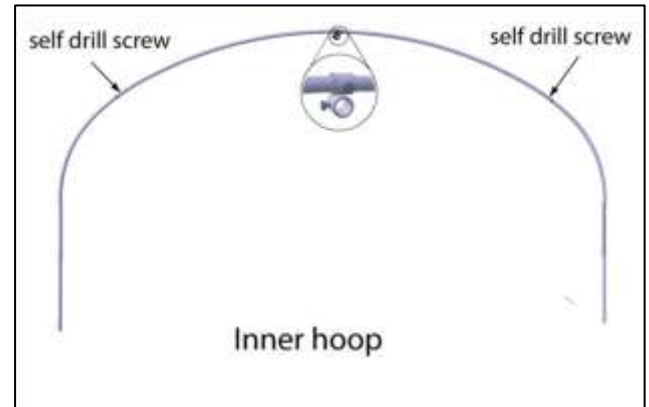
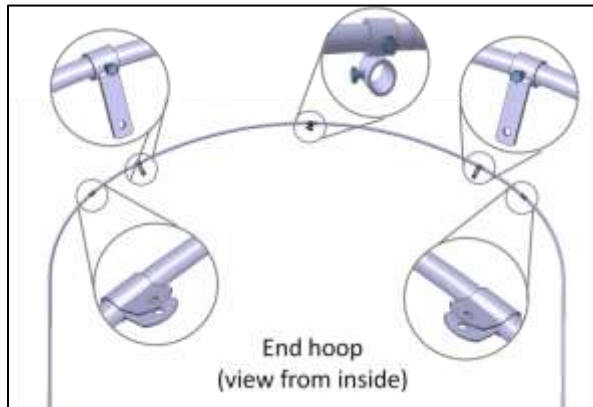

Tip! If you have ordered crop/tie bars, it's easier to put the KH25 fittings onto the hoops now.

- 2 Fix the two top part-hoops together with the E25 fitting. Fix the hoop leg to the top part-hoop with the self-drill screws, using a cordless drill.
- 3 (OPTION) If you have ordered the Side Rail Option:
  - a. Slide an M25 fitting onto the leg of each end hoop.
  - b. Slide an H25 fitting onto the leg of each inner hoop.
 Set the M25 fitting and the H25 fittings at approximately 90cm from the bottom of the hoop.

- 4 Slot a KH20 fitting over the second Foundation Tube from each end of the polytunnel. This is to hold the bottom end of the corner diagonal.
- 5 (OPTION) If you have ordered the Base Rail Option, slide an M20 fitting over each corner Foundation Tube.
- 6 Put an A20 fitting onto each foundation tube. On the corner foundation tubes, set the A20 fitting to about 18cm above ground level. On the inner foundation tubes, set the A20 fittings about 5cm lower.

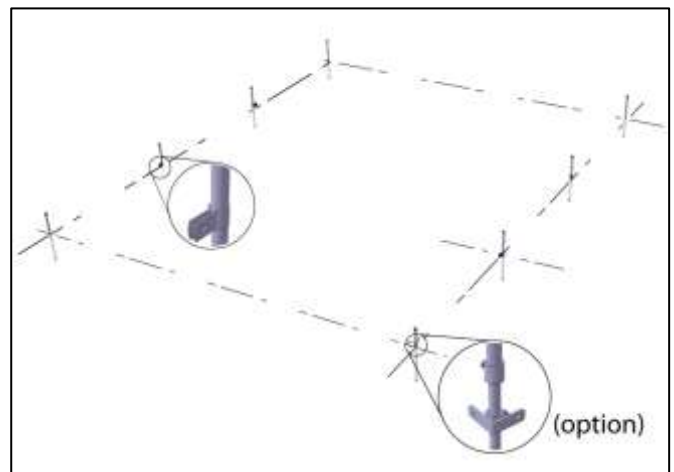

- 7 Slot the assembled hoops onto the Foundation Tubes. Make sure the end hoops are positioned so that the bolt heads are inside the polytunnel.

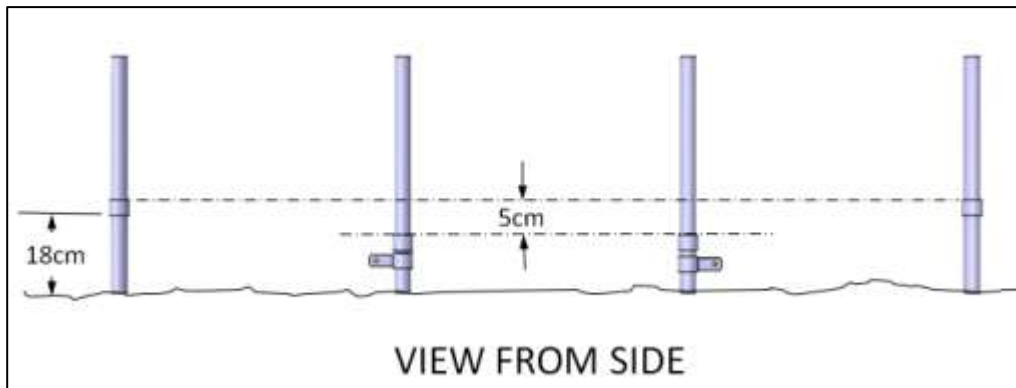

- 8 Make sure the end hoops are set approximately 5cm higher than the inner hoops. (The inner hoops will be raised later to tension the polythene.) The end hoops should be approximately 18cm above ground level. Lock in place with the A20 fittings.
- 9 Slot the ridge tube into the E25 fittings, starting with the plain-ended ridge tube. Set the end of the ridge tube flush with the E25 fitting and tighten the bolt to secure in place.
- 10 Slot a swaged ridge tube into the end of the previous ridge tube until you reach the end of the polytunnel. Tighten the bolts in the E25 fittings to secure the ridge tubes in place.
- 11 Insert a plastic plug into each end of the ridge tube.
- 12 Fit the four corner diagonals. Fix to the KH20 fitting on the Foundation Tube first using an M8 x 30 bolt & nylock nut. Then fix to the KH25 fitting on the end hoop.

**Tip!** Put the bolts through from the outside so that the thread of the bolt doesn't protrude into the polythene.

- 13 Set the end hoops so that they are vertical (looking from the side) by adjusting the position of the KH25 fittings.

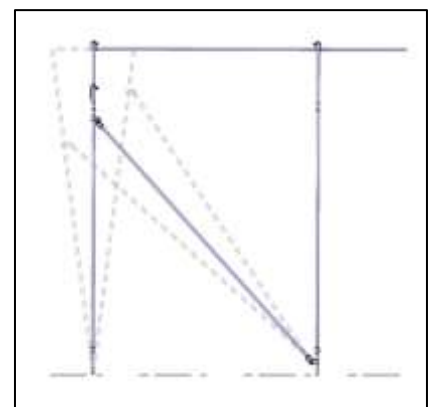
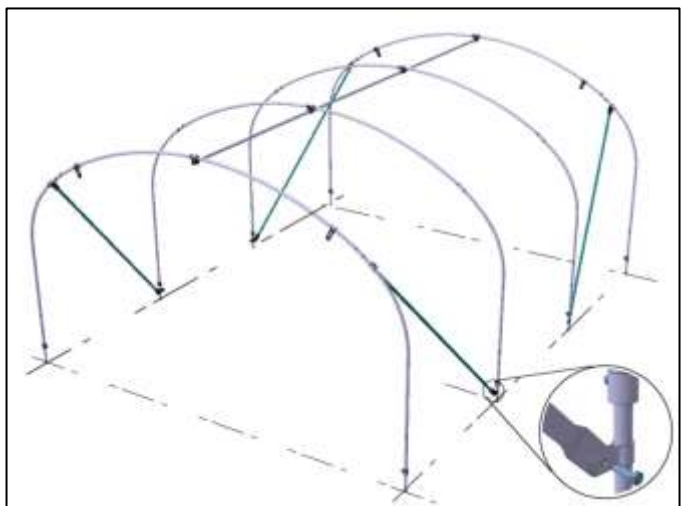
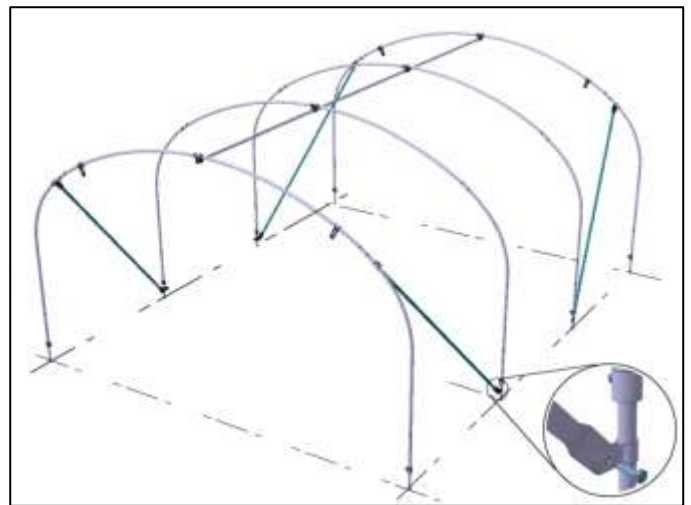

### 5. TIMBER END FRAME ASSEMBLY & INSTALLATION

- 1 For each Timber End Frame you will need:
  - a. 3 pieces of timber at 89mm x 38mm x 2400mm long
  - b. 2 corner joint plates
  - c. 1 batten 38mm x 19mm x 900mm long
  - d. 18 twist nails 30mm long
  - e. 2 nails 125mm long
- 2 Lay the timber end frames out on a flat surface in the arrangement shown.

Tip! It's easier to make the frame of the door first and then build the End Frame around it.

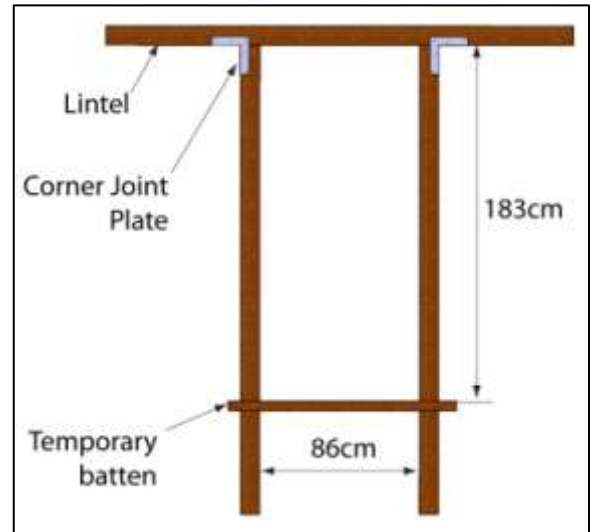

- 3 Use the 30mm twist nails to fix the corner joint plates (9 nails each) and then nail through the lintel into the top of the door post with the 125mm nails.

Tip! Pre-drill the lintel with a 5mm hole for the 125mm long nails.

- 4 Nail a temporary batten across the door posts at 185cm below the lintel. This will rest on the ground when you are installing the Timber End Frame and set the lintel to the correct height.

- 5 Dig two holes for the door posts at each end of the polytunnel, approximately 55cm deep.

- 6 Slot the door posts into the excavated holes and set the end frame vertical in both directions.

- 7 Position the D25 fittings on the end hoop to accept the lintel. Mark the lintel for mitring if necessary and drilling to bolt to the D25 fittings.



- 8 Fix the Timber End Frame to the D25 fittings with M8 x 50 coach bolts and nuts. Note, the Timber End Frame is located on the inside face of the tabs on the D25 fittings.

- 9 Back-fill the excavated holes and compact the soil. Remove the temporary battens.

- 10 If you are trenching the polythene, create a rebate around the Timber End Frame for fixing the polythene. Use battens 38mm x 19mm and 50mm long nails at about 15cm apart.





## 6. TIMBER BASE RAIL (OPTION)

- 1 Set the M20 fittings on the corner Foundation Tubes so that the holes in the plate are about 5cm above ground level.
- 2 Start at one end of the polytunnel, at the door post. Place the end of the timber 89mm x 38mm x 2400mm long up to the side of the door post. Mark the timber to the outside face of the M20 fitting and cut to length.
- 3 Re-position the piece of timber and mark through the hole on the M20 fitting and drill the timber to accept an 8mm diameter bolt.

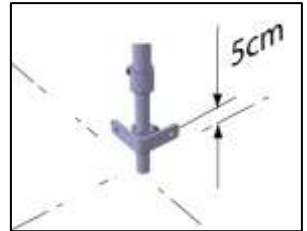

Tip! Use the timber offcuts wherever they are long enough.

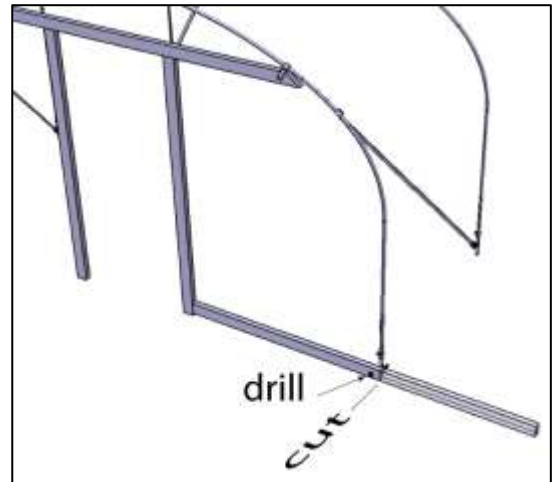
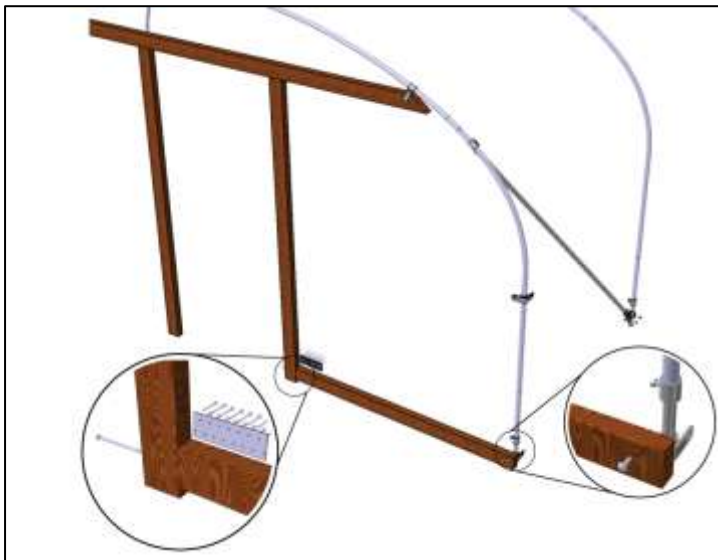

- 4 Bolt the timber to the M20 fitting with an M8 x 50 coach bolt and nut.
- 5 Using a flat nail plate, fix the timber to the door post with 30mm long twist nails. Nail through the door post into the end of the timber with a 125mm long nail.

- 6 Lay the next timber along the side of the polytunnel, flush with the outside of the timber base rail on the end of the polytunnel. Mark through the hole in the M20 fitting and drill to accept an M8 bolt.
- 7 Bolt the timber to the M20 fitting with an M8 x 50 coach bolt and nut.

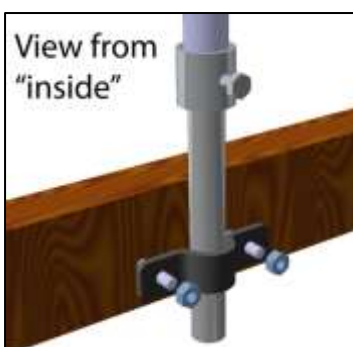

- 8 On the next Foundation Tube, position an SC20 fitting over the Foundation Tube and mark through the two holes. Drill to accept an M8 bolt and fix in place with two M8 x 65 coach bolts and nuts.
- 9 Continue until you reach the end of the polytunnel and trim the last timber to length.

## 12ft Wide Polytunnel Assembly Instructions

- 10 Where the timber rails join end-to-end, connect together with a timber joint plate and 30mm long twist nails.

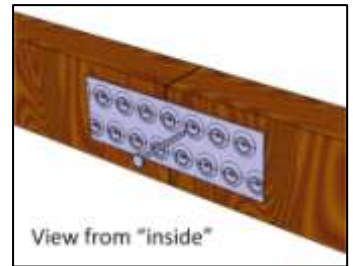

- 11 Check that the timber base rail is straight and adjust the SC20 fittings if necessary.
- 12 If you are fixing the main cover to the base rail, create a rebate around the Timber End Frame and along the base rail for fixing the polythene. Use battens 38mm x 19mm and 50mm long nails, about 15cm apart.

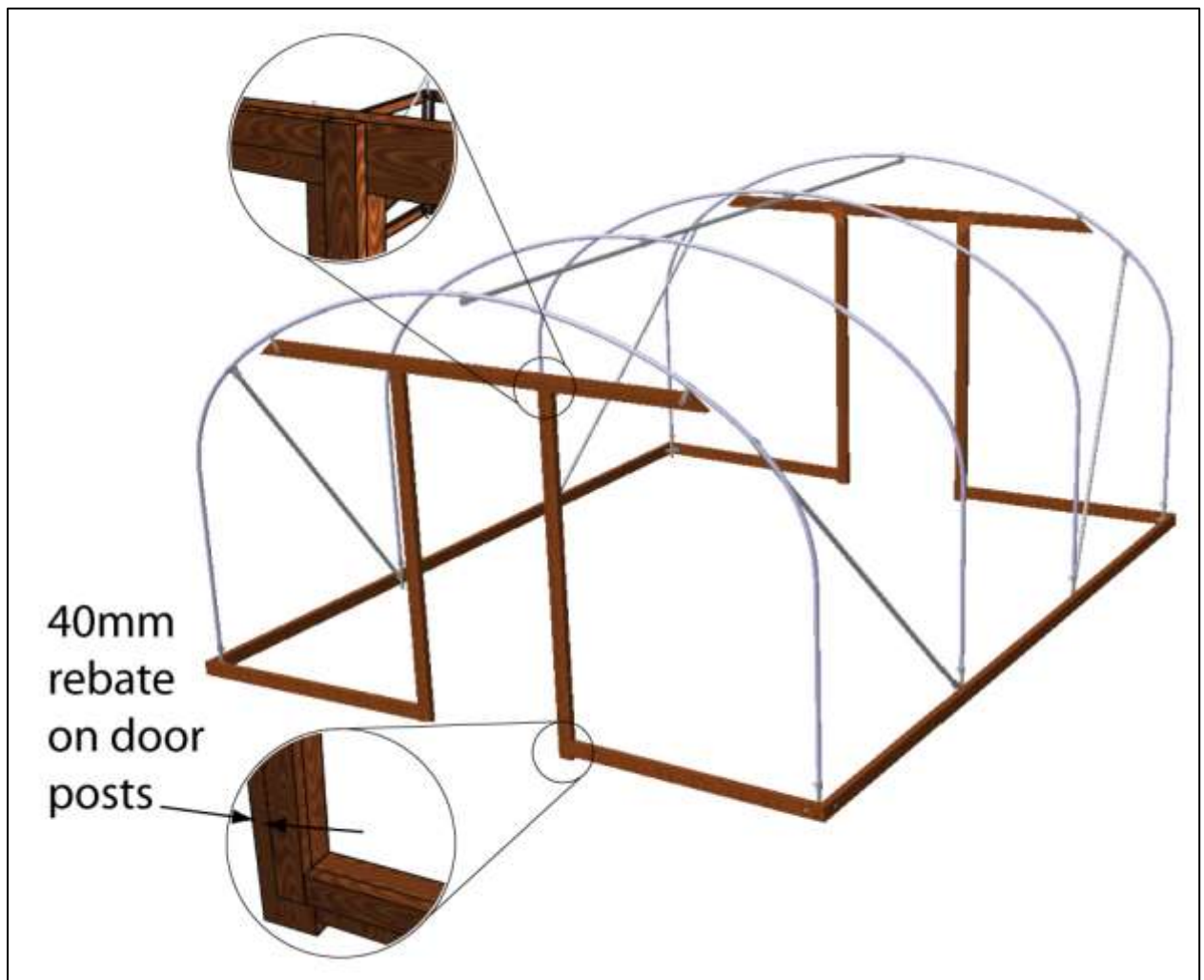

### 7. TIMBER SIDE RAIL (OPTION)

- 1 Set the M25 fittings and H25 fittings 90cm above the M20/SC20 fittings on the Foundation Tubes.
- 2 Start at one end of the polytunnel, at the door post. Place the end of the timber 89mm x 38mm x 2400mm long up to the side of the door post. Mark the timber to the outside face of the M25 fitting and cut to length.
- 3 Re-position the piece of timber and mark through the hole on the M25 fitting and drill the timber to accept an 8mm diameter bolt.

Tip! Use the timber offcuts wherever they are long enough.

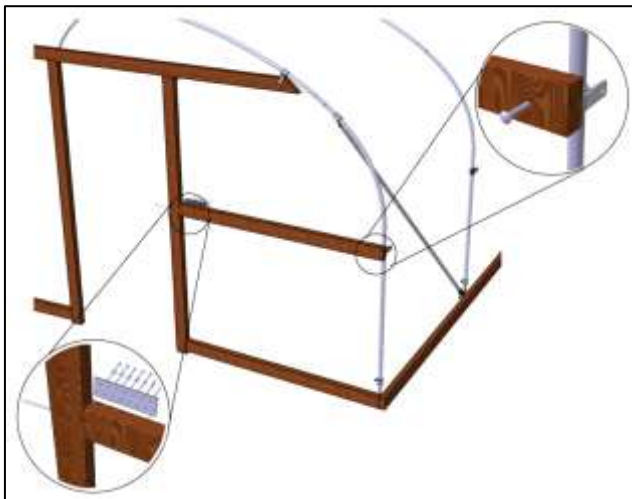

- 6 Hold the next timber along the side of the polytunnel, flush with the outside of the timber side rail on the end of the polytunnel. Mark through the hole in the M25 fitting and drill to accept an M8 bolt.
- 7 Bolt the timber to the M25 fitting with an M8 x 50 coach bolt and nut.

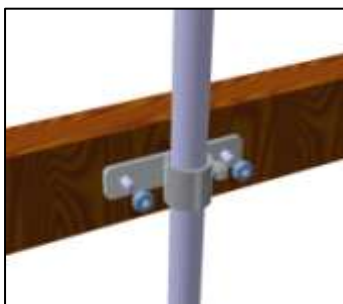

- 8 On the next hoop, mark the timber through the two holes in the H25 fitting. Drill to accept an M8 bolt and fix in place with two M8 x 50 coach bolts and nuts.
- 9 Continue until you reach the end of the polytunnel and trim the last timber to length.

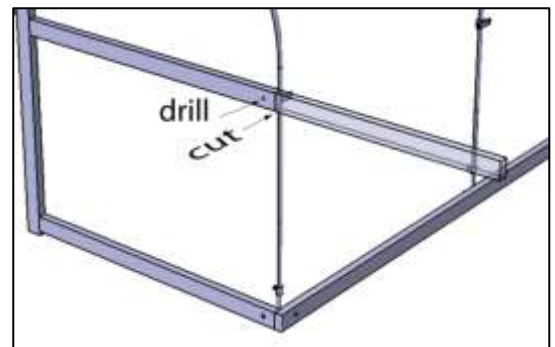
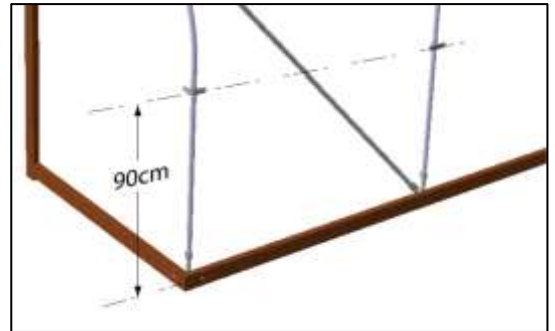

- 4 Bolt the timber to the M25 fitting with an M8 x 50 coach bolt and nut.
- 5 Using a flat nail plate, fix the timber to the door post with 30mm long twist nails. Make sure the timber is parallel to the base rail. Nail through the door post into the end of the timber with a 125mm long nail.



- 10 Where the timber rails join end-to-end, connect together with a timber joint plate and 30mm long twist nails.

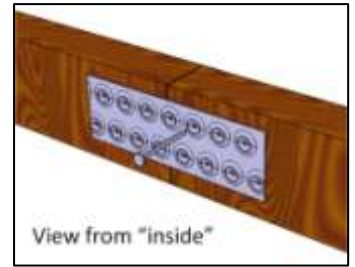
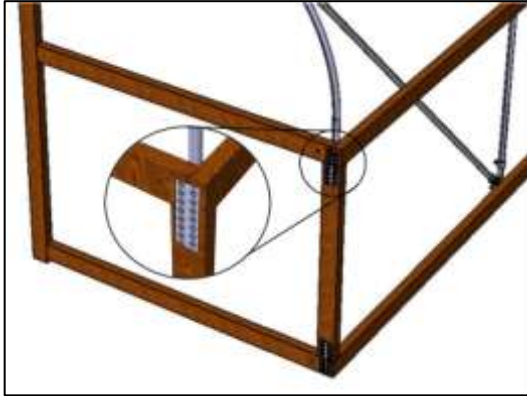

- 11 For each corner, cut a piece of timber to fit between the base rail and the side rail.
- 12 Fix this vertical timber between the base rail and the side rail with a timber joint plate at each end using 30mm long twist nails.

Tip! Pre-nail the timber joint plates onto the vertical timber before you put it in place. Everything is much more rigid whilst you are nailing.



## 8. ROLL UP CURTAIN (OPTION)

- 1 Cut the 2m wide roll of polythene down the centre (to 1m wide).
- 2 Join the lengths of curtain tube together starting with the plain-ended piece. Fix the tubes together with a self-drill screw. Cut the last piece to length so that the overall length of the tube is 30cm shorter than the gap between the vertical corner timbers.

Tip! The curtain operates better if the gearbox is positioned at the "low" end of the 'tunnel.

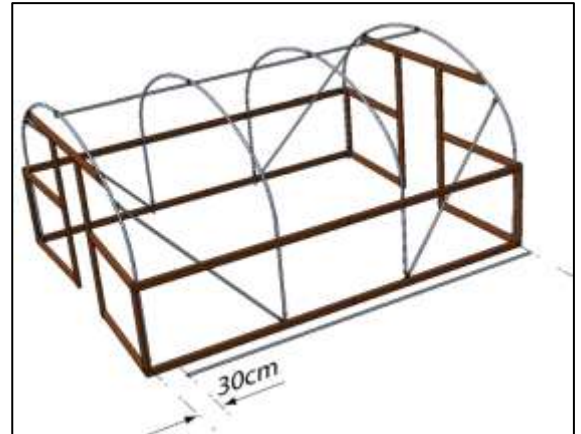
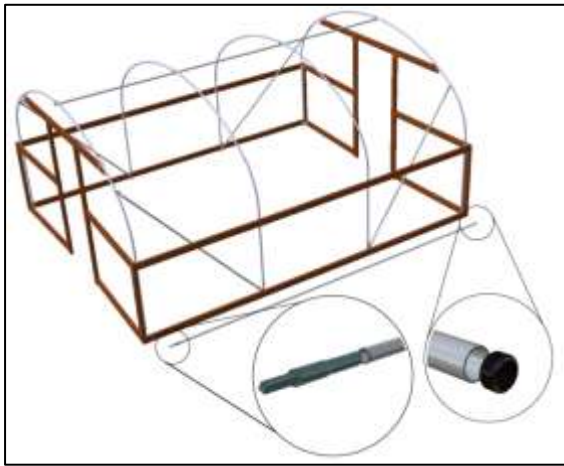

- 3 Slot the drive tube end into the curtain tube at the end where you want to operate the gearbox. Fix together with a self-drill screw, 65-70mm from the swage shoulder (to avoid drilling into the square shaft).

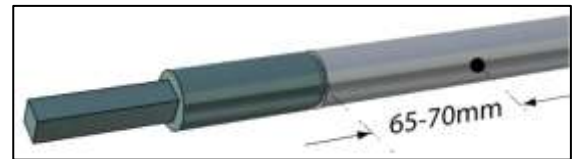

- 4 Slot a black PVC plug into the other end of the drive tube.
- 5 Roll out the 1m wide polythene along the side of the polytunnel and lay the drive tube on top, close to one edge.
- 6 With the PVC clips, clip the polythene to the drive tube at approximately every 30cm, keeping the polythene as straight as possible.

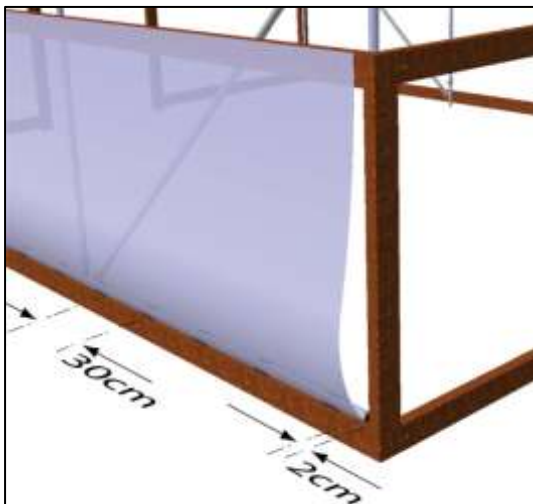
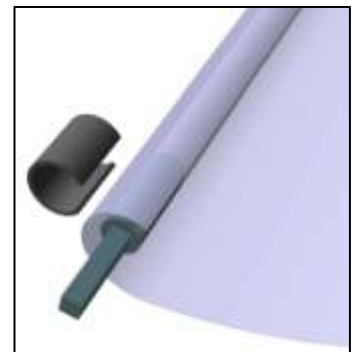

- 7 Rest the drive tube on top of the base rail with approximately 2cm gap between the end of the drive tube and the vertical corner timber. Staple the top edge of the polythene to the side rail, flush with the top edge. At each end of the drive tube, trim of the surplus polythene.

- 8 Take up the slack in the polythene by rolling the drive tube into the polythene. Slot the gearbox assembly onto the square shaft and slide the guide tube into tube on the gearbox bracket.
- 9 Hold the guide tube onto the inside faces of the base rail and side rail and fix it to the base rail with an M8 x 50 coach screw.



- 10 With the gearbox handle, wind the curtain up to the side rail. Fix the top end of the guide tube to the side rail with an M8 x 50 coach screw. Fit a PVC plug into the top end of the guide tube.

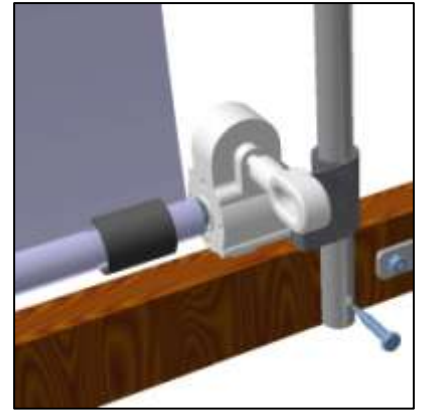

- 11 Check that the curtain rolls up parallel to the base rail and side rail and adjust the PVC clips if necessary.
- 12 Cut a notch out of the base rail where the gearbox touches to allow the drive tube to rest directly on top of the base rail.

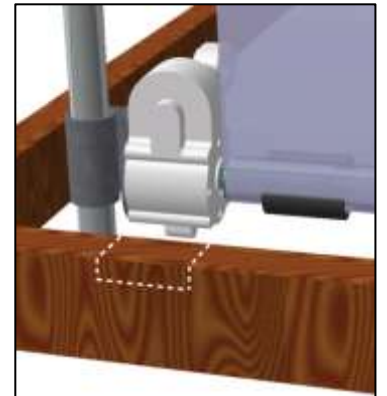

**9. END PANELS & SIDE NETTING (INCLUDED WITH TIMBER SIDE RAIL OPTION)**

- 1 Cut a piece of polythene to fit over the panel at the side of the doorway and around the side of the polytunnel by approximately 40cm (approximately 1m x 2m).
- 2 Staple the polythene over the end frame, around the side of the polytunnel to overlap the curtain.
- 3 Unroll the net along the side of the polytunnel.

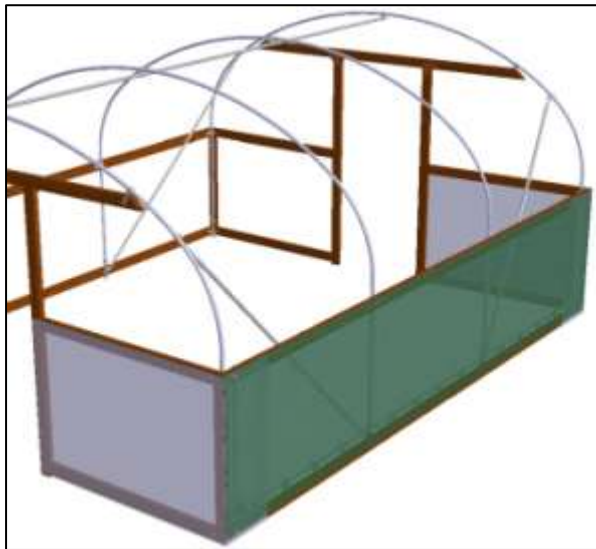
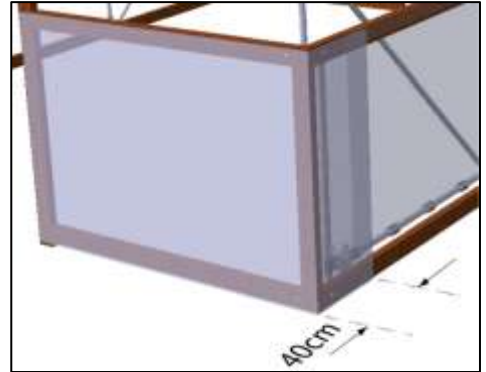

- 4 Staple the net to the side rail, flush with the top edge. Staple the net to the two vertical corner rails and to the base rail.

- 5 Batten over the net and end panels in the positions shown.

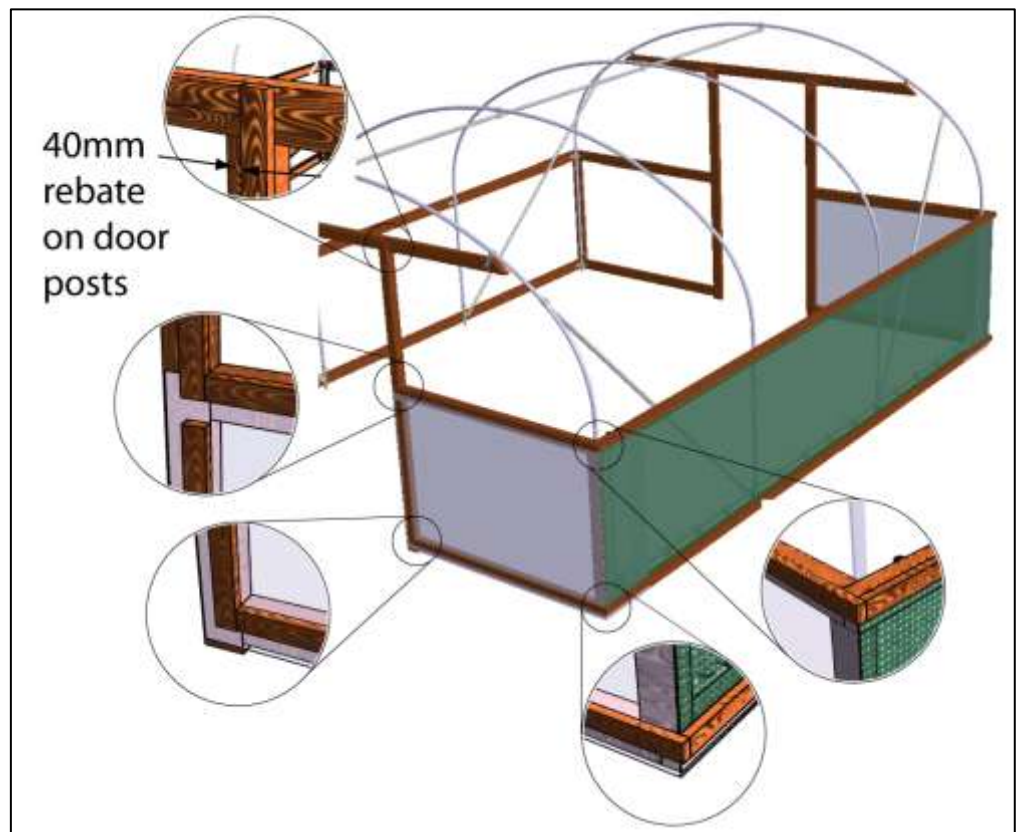

**10. FITTING THE ANTI HOT SPOT TAPE**

- 1 The Anti Hot Spot Tape is applied to the hoops of the polytunnel where the polythene would touch.
- 2 Starting just above the A20 fitting on the Foundation Tube, place the Anti Hot Spot Tape on the outside face of the hoop. On the inner hoops the tape should be central on the tube. On the end hoops the tape should be on the “corner” of the tube.

Tip! Don't fit the Anti Hot Spot Tape until you're ready to sheet – it may get damaged if the weather is wet and windy.

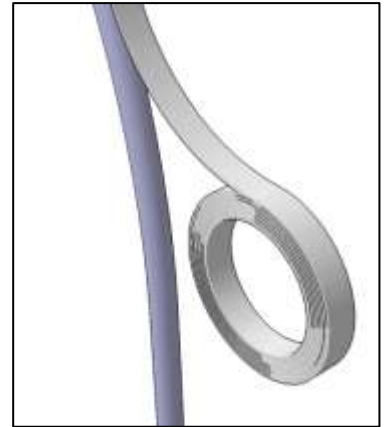

- 3 Tape over any sharp edges, bolt heads and metal faces that the polythene may come into contact with.



### 11. FITTING THE POLYTHENE – TRENCHING METHOD

- 1 Dig a trench around the perimeter of the polytunnel, approximately 15cm away from the Foundation Tubes. The trench should be approximately 30cm wide x 30cm deep.

Tip! Wait for a calm and preferably warm day to sheet your polytunnel. It will be much easier and you'll probably do a better job!

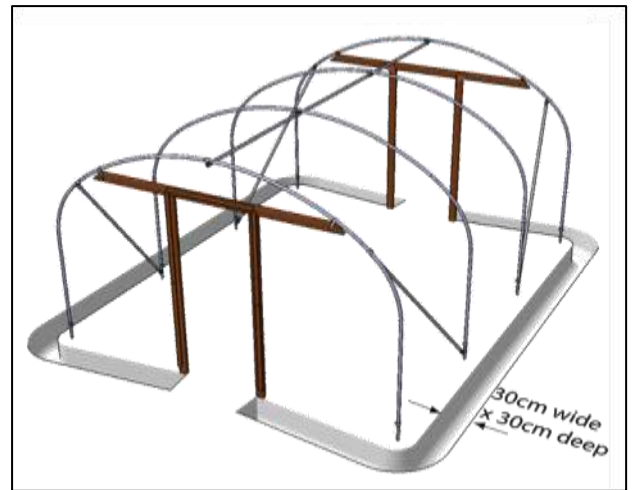

- 2 Unroll and unfold the polythene and drape it over the polytunnel framework with an equal amount over each side and each end.
- 3 Carefully slice the polythene diagonally from the top corners of the doorway. Trim the bottom off the central flap so that it hangs approximately 30cm below the door lintel.

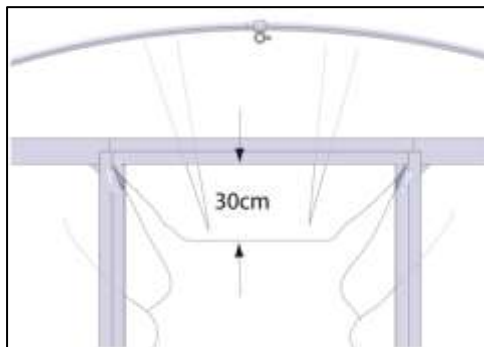

- 1 Use a full batten to fit in the rebate above the doorway.
- 2 Place the batten underneath the flap of polythene and roll the batten into the polythene, up to the rebate. Nail the batten in place. Note, it is preferable to have a couple of small pleats in the flap of polythene.
- 3 Repeat at the other end, **PULLING THE POLYTHENE AS TIGHT AS POSSIBLE.**



- 4 Start back-filling the trench along the sides of the polytunnel, working from the centre towards each end. Try to get the polythene tight by pulling on the surplus polythene as you fill the trench. Continue right up to the door posts, pulling the polythene towards to doorway.

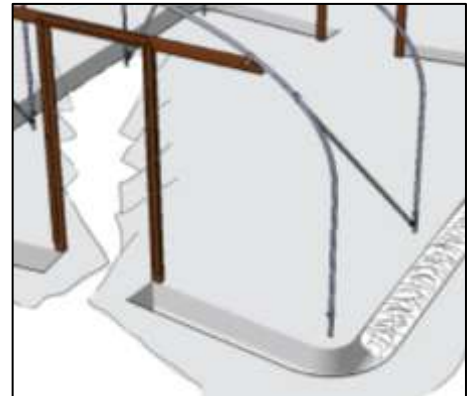

- 5 Now fix the polythene to the door posts. The polythene is pulled into the doorway and pleated. Trap the polythene behind the batten as you nail the batten into the rebate. Use 50mm long nails at approximately 10cm apart..

Tip! Pre-nail the battens so they're ready to fix the polythene quickly.

Tip! Fold the pleats downwards so that they don't collect rainwater.



- 6 Trim off the surplus polythene in the doorway.

Tip! To avoid the back-filled trench becoming water-logged, prick the polythene at the bottom of the trench with a garden fork.

- 7 Raise the inner hoops to tension the polythene.

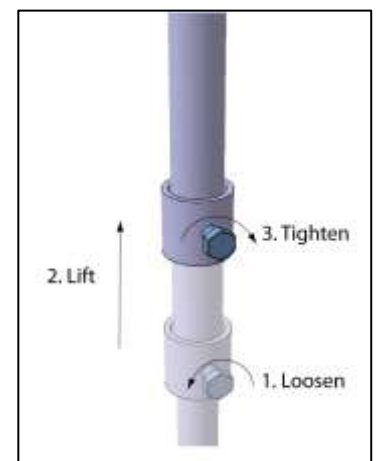

### 12. FITTING THE POLYTHENE – POLYTHENE TO BASE RAIL

- 1 Unroll and unfold the polythene and drape it over the polytunnel framework with an equal amount over each side and each end.
- 2 Carefully slice the polythene diagonally from the top corners of the doorway. Trim the bottom off the central flap so that it hangs approximately 30cm below the door lintel.
- 4 Use a full batten to fit in the rebate above the doorway.

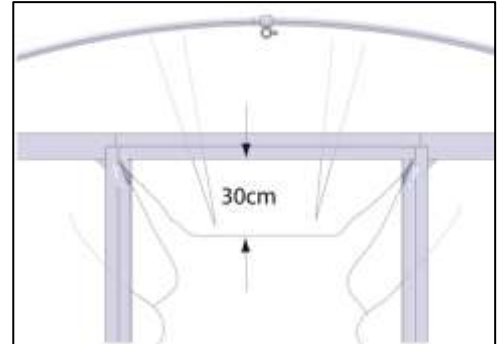

- 3 Place the batten underneath the flap of polythene and roll the batten into the polythene, up to the rebate. Nail the batten in place. Note, it is preferable to have a couple of small pleats in the flap of polythene.
- 4 Repeat at the other end, PULLING THE POLYTHENE AS TIGHT AS POSSIBLE.

- 5 Starting at the centre of one side, batten the polythene to the base rail. Hold the batten under the edge of the polythene and carefully cut the polythene in line with the ends of the batten to create a flap, up to the bottom edge of the base rail.

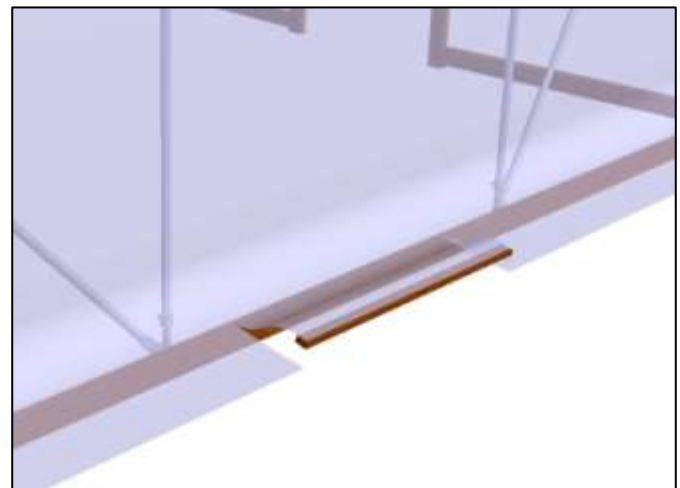
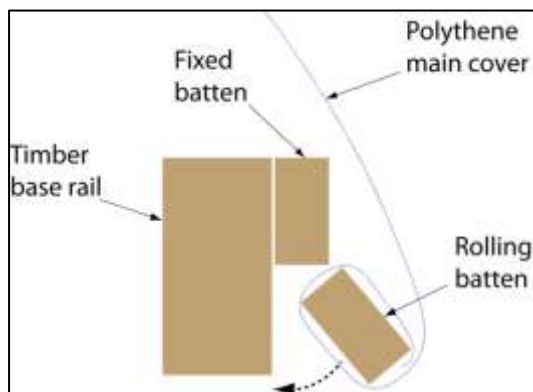

- 6 Roll the batten into the polythene up to the rebate and nail the batten to the base rail with 50mm long nails, approximately 7 nails per batten.
- 7 Do the same at the opposite side of the polytunnel but try to tension the polythene by levering the edge of the batten against the rebate.
- 8 Continue towards each end of the polytunnel, alternating between each side.

9 Continue around the corners, pulling the polythene towards to doorway.

10 Now fix the polythene to the door posts. The polythene is pulled into the doorway and pleated. Trap the polythene behind the batten as you nail the batten into the rebate. Use 50mm long nails at approximately 10cm apart.

Tip! Fold the pleats "downwards" so that they don't collect rainwater.

Tip! Pre-nail the battens so they're ready to fix the polythene quickly.



11 Trim off the surplus polythene in the doorway.

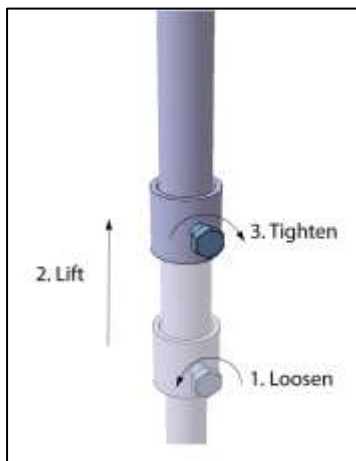

12 Raise the inner hoops to tension the polythene.

**13. FITTING THE POLYTHENE – POLYTHENE TO SIDE RAIL**

- 1 Unroll and unfold the polythene and drape it over the polytunnel framework with an equal amount over each side and each end.
- 2 Carefully slice the polythene diagonally from the top corners of the doorway. Trim the bottom off the central flap so that it hangs approximately 30cm below the door lintel.
- 5 Use a full batten to fit in the rebate above the doorway.

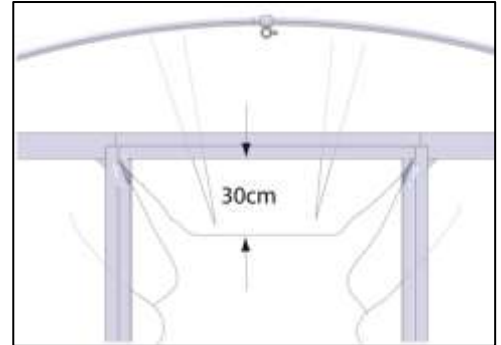

- 3 Place the batten underneath the flap of polythene and roll the batten into the polythene, up to the rebate. Nail the batten in place. Note, it is preferable to have a couple of small pleats in the flap of polythene.
- 4 Repeat at the other end, PULLING THE POLYTHENE AS TIGHT AS POSSIBLE.

- 5 Starting at the centre of one side, batten the polythene to the side rail. Hold the batten under the edge of the polythene and carefully cut the polythene in line with the ends of the batten to create a flap, up to the bottom edge of the side rail.
- 6 Roll the batten into the polythene up to the rebate and nail the batten to the side rail with 50mm long nails, approximately 7 nails per batten.

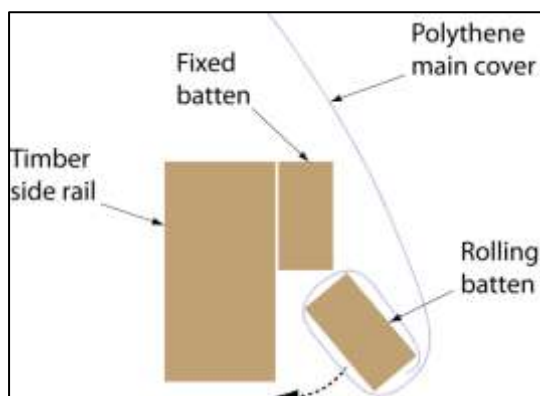
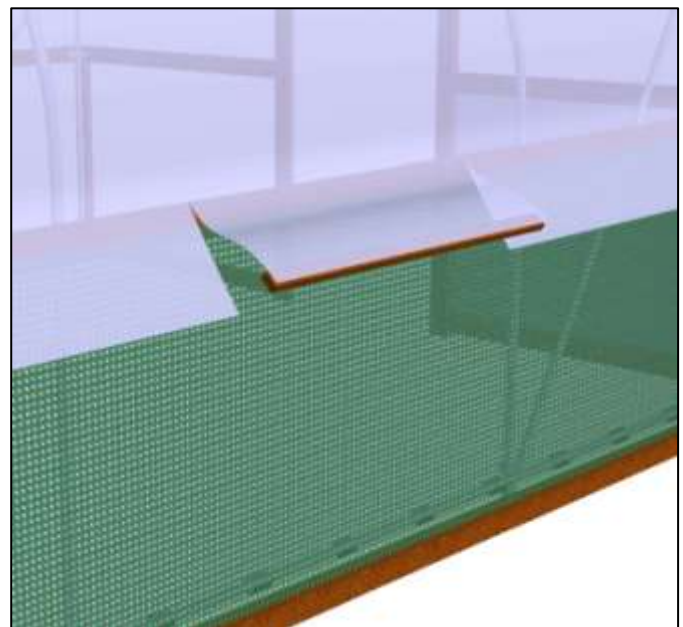

- 7 Do the same at the opposite side of the polytunnel but try to tension the polythene by levering the edge of the batten against the rebate.
- 8 Continue towards each end of the polytunnel, alternating between each side.

- 9 Continue around the corners, pulling the polythene towards to doorway.
- 10 Now fix the polythene to the door posts. The polythene is pulled into the doorway and pleated. Trap the polythene behind the batten as you nail the batten into the rebate. Use 50mm long nails at approximately 10cm apart.

Tip! Fold the pleats "downwards" so that they don't collect rainwater.

Tip! Pre-nail the battens so they're ready to fix the polythene quickly.



- 11 Trim off the surplus polythene in the doorway.

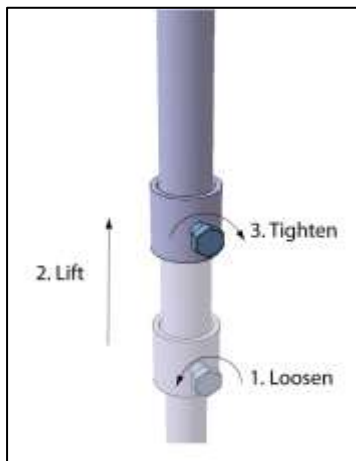

- 12 Raise the inner hoops to tension the polythene.

### 14. DOOR ASSEMBLY & INSTALLATION

- 1 For each door frame you will need:
  - a. 2 pieces of timber at 42mm x 38mm x 1830mm long (verticals)
  - b. 3 pieces of timber at 42mm x 38mm x 770mm long (horizontals)
  - c. 4 Corner Joint Plates
  - d. 2 Plywood Triangles
  - e. 46 twist nails 30mm long
  - f. 6 nails 75mm long

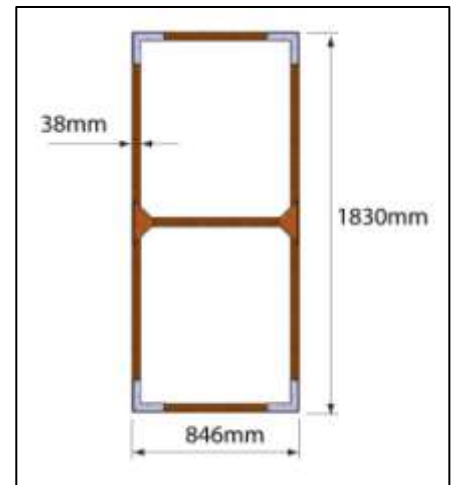

- 2 Lay the door frame out on a flat surface in the arrangement shown. Note, the visible face of the timber is 38mm wide (not 42mm).

- 3 Using the 30mm twist nails, nail the Corner Joint Plates over the corners of the door. Nail the 2 Plywood Triangles over the joints of the mid-rail to the verticals, 5 nails per triangle. Set the triangles approximately 5mm from the edge of the door.

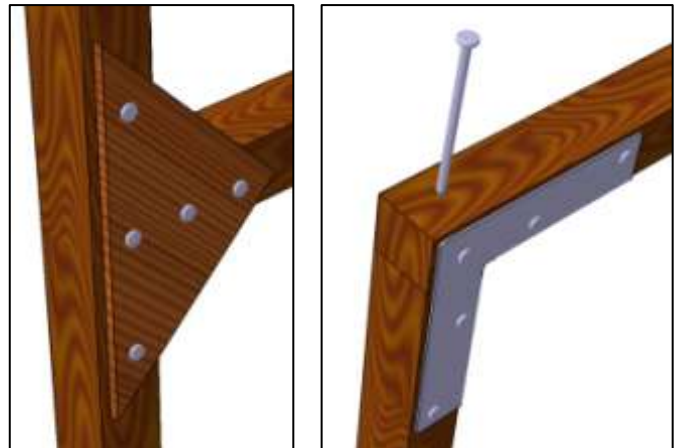

- 4 Stand the door on its side and nail through the door verticals into the ends of the door horizontals with the 75mm nails

- 5 For cladding each door you will need:
  - a. 3 battens at 38mm x 19mm x 846mm (cut to length)
  - b. 4 battens at 38mm x 19mm x 858mm (cut to length)
  - c. Piece of door polythene, 1m x 1m
  - d. Piece of door net, 1m x 1m
  - e. 63 nails 50mm long

- 6 Lay the door on its inside face (plywood triangles down). Lay the polythene over the bottom half of the door and the net over the top half of the door. The polythene and net will overlap on the middle door horizontal by the thickness of the timber (38mm).

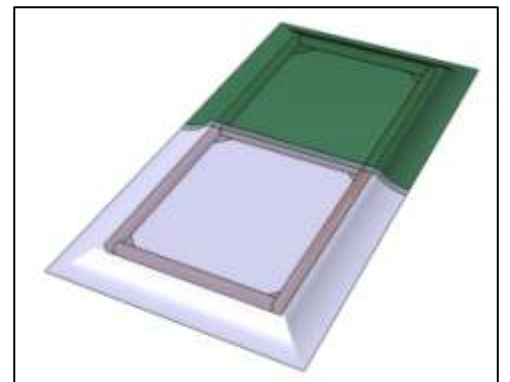

- 7 Hold the polythene and net in place with staples using a staple gun or stapler. Try to get the polythene and net tight when stapling to the door frame.

**Tip!** Pre-nail the battens before you clad the door to get the job done quicker!

- 8 Starting with the mid-rail, nail a batten over the polythene and net. Use 50mm long nails, 9 nails per batten. Next nail on the end battens and finally the side battens.

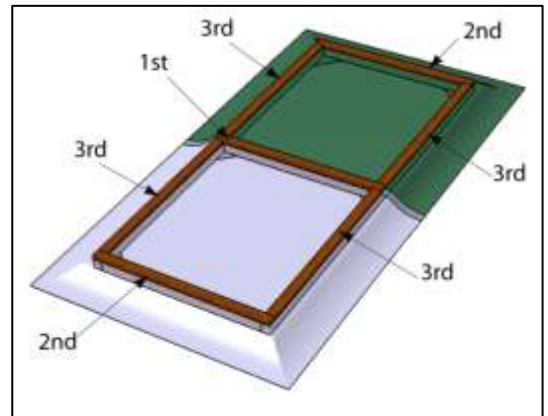

- 9 Trim off the surplus polythene and net.

- 10 Screw the hinges onto the front face of the door, ensuring that the door is hinged on the side which you want.

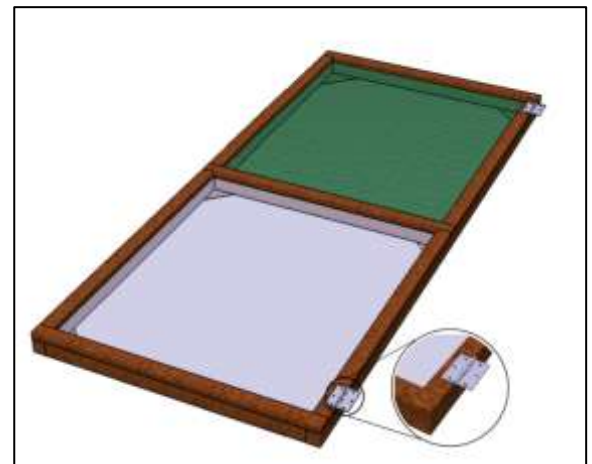

- 11 Position the door with the end frame, resting on packing pieces to set the gap around the door. Screw the hinges to the door post.

- 12 Screw the auto gate latch and latching bar to the door post and door vertical, respectively.

- 13 Drill a hole through the door post for the pull-string. The polyester cord (pull-string) is tied around the sneck of the gate latch, threaded through the hole and a loop tied on the end. This operates the latch from the inside of the Polytunnel.

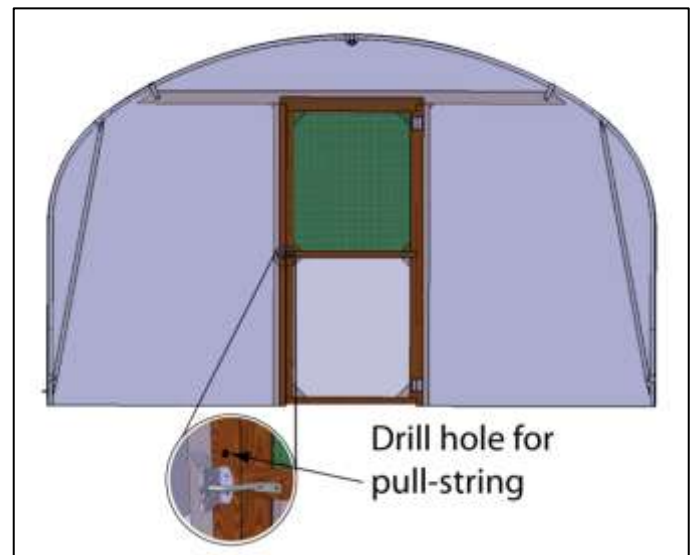

If you are unsure about any part of the assembly procedure you can contact our office between 8:30am and 5:00pm, Monday to Friday on 01282 501252



**PARTS LIST**

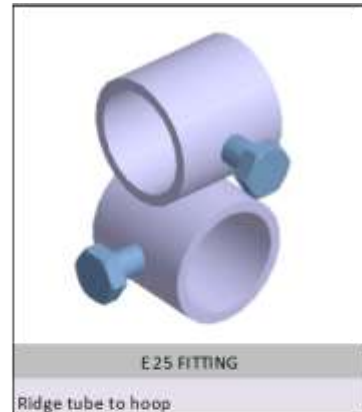
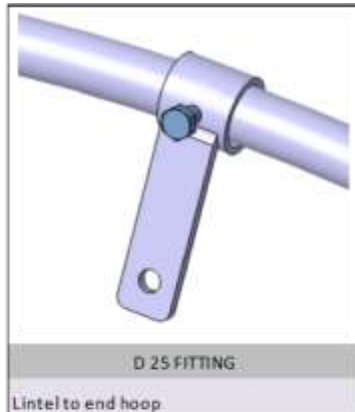
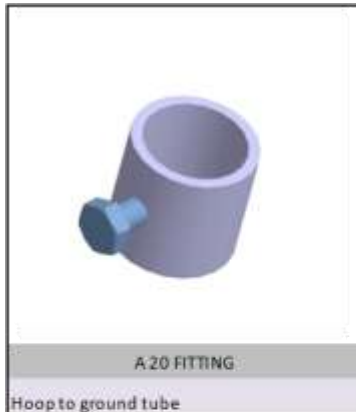

**PARTS LIST (continued)**

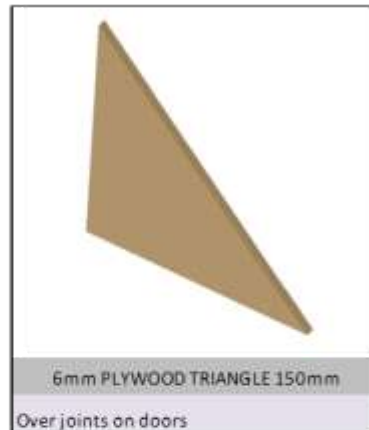

**PARTS LIST (continued)**



**GROUND ANCHOR PLATE & STARLOCK**  
Over ground tube



**75mm BUTT HINGE (PAIR) BZP**  
Door to door frame



**AUTO GATE LATCH BZP**  
To hold the door closed



**MANUAL GEARBOX 8.5:1**  
Operates the side roll up curtain



**GEARBOX MOUNTING BRACKET**  
Gearbox to guide tube



**GEARBOX HANDLE 1.2m**  
To operate the gearbox



**GEARBOX GUIDE TUBE (1000mm)**  
Supports the gearbox guide bracket



**GEARBOX SQUARE DRIVE SHAFT**  
Drive tube to gearbox



**PVC CURTAIN TUBE CLIP**  
To clip the curtain polythene to drive tube



**PVC PLUG Dia 25mm**  
Ends of ridge tube, drive tube, guide tube



**ANTI HOT SPOT TAPE 25mm**  
To insulate the polythene from the steel



## 12ft Wide Polytunnel Assembly Instructions

### **POLYTUNNEL MAINTENANCE**

Your polytunnel should require very little maintenance during normal use.

1. "Moving" parts of your polytunnel are the most susceptible to damage from extreme weather conditions. These include items like doors and roll up curtains. To minimise the likelihood of damage, ensure that the doors and curtains are operating correctly and adjust where necessary.
2. Minor tears and damage to polythene can be repaired using Polythene Repair Tape. Before applying Repair Tape, make sure the polythene is clean and dry. Apply pressure from both sides of the polythene when applying the Repair Tape. If possible, apply the Repair Tape to both sides of the polythene. Always use sharp scissors when cutting the Repair Tape.
3. Major damage to the polythene cover will require a complete replacement polythene cover.
4. When replacing the polytunnel cover, check the Anti Hot Spot Tape for degradation and de-lamination of the friction-free surface. Replace the Anti Hot Spot if necessary or repair with Anti Hot Spot Repair Tape.
5. The polythene cover will perform better and is likely to last longer if it is clean. Cleaning the polythene can be done with soapy water and a sponge or soft brush. Cleaning should only be necessary once every year unless the polytunnel is sited below overhanging tree branches.
6. Any minor damage should be rectified as soon as it is apparent to avoid possible catastrophic failure of the polytunnel framework.